



# AIR TOOLS CATALOG

- IMPACT WRENCHES ■ DRIVERS ■ RATCHET WRENCHES
- SANDERS ■ POLISHER ■ GRINDERS ■ DRILLS / SPOTMILLS
- CUTTING TOOLS ■ OTHERS



MADE IN JAPAN



## Functional and Sophisticated Design

Well designed tools that have fully biotechnological and easy to use.

## Highest Perfection

We provide excellence to our customers' needs, in all respects, such as quality, function, user friendliness, safety, noise control and warranty.

高品質  
High quality

高性能  
High performance

**MADE  
IN JAPAN**

*That is our promise of having  
"SI" marked products.*



ISO9001  
Management system certificate



We, Shinano Inc. were established in 1949 and Specialized our air tools in 1969. We have achieved excellent results and built on our experience to meet our own requirements for quality, accuracy, safety and user friendliness. Our production ratio is one of the largest in the world. We cover more than 100 types of tools.





05-13

## IMPACT WRENCHES

<b>1/4" SQ.DR.</b>	<b>06</b>
SI-1310	06
<b>3/8" SQ.DR.</b>	<b>06-07</b>
SI-1301	06
SI-1305	06
SI-1315	06
SI-1355	06
SI-1356	07
SI-1365	07
SI-1370	07
<b>1/2" SQ.DR.</b>	<b>07-09</b>
SI-1456	07
SI-1650AH	07
SI-1610	08
SI-1610SR	08
SI-1420T	08
SI-1422T	08
SI-1440T	08
SI-1442T	08
SI-1480A	09
SI-1482A	09
SI-1480ASR	09
SI-1482ASR	09
<b>3/4" SQ.DR.</b>	<b>10</b>
SI-1540B	10
SI-1546B	10
SI-1540BSR	10
SI-1546BSR	10
<b>1" SQ.DR.</b>	<b>11-12</b>
SI-1700	11
SI-1706	11
SI-1710	11
SI-1760T	12
SI-1766T	12
SI-1770T	12
SI-1776T	12
SI-1850B	12
SI-1856B	12
ACCESSORIES	13

## IMPACT WRENCHES

14-16

## DRIVERS

<b>IMPACT DRIVERS</b>	<b>15-16</b>
SI-1052	15
SI-1060	15
SI-1062	15
SI-1065	15
SI-1070	15
SI-1301D	15
SI-1356D	15
SI-1365D	16
SI-1370D	16

## DRIVERS

17-20

## RATCHET WRENCHES

21-32

<b>SCREW DRIVERS</b>	<b>16</b>
SI-1140	16
SI-1161	16
SI-1166A	16
SI-1166-8A	16
SI-1170	16

## RATCHET WRENCHES

<b>1/4" SQ.DR.</b>	<b>18</b>
SI-1107B	18
SI-1200B	18
SI-1207	18
SI-1251	18
<b>3/8" SQ.DR.</b>	<b>18-20</b>
SI-1108B	18
SI-1205B	18
SI-1208	19
SI-1252	19
SI-1261/SI-1261S	19
SI-1320A	19
SI-1340B	19
SI-1208Q	19
SI-1241	20
<b>1/2" SQ.DR.</b>	<b>20</b>
SI-1262/SI-1262S	20
SI-1325A	20
SI-1345B	20
SI-1435	20
<b>HEX17mm Through</b>	<b>20</b>
SI-1288(S)	20

## SANDERS

<b>BELT SANDERS</b>	<b>22</b>
SI-2700	22
SI-2700L/SI-2700LS	22
SI-2800	22
SI-2830	22
SI-2760	22
FOR SI-2760 ACCESSORIES	22
<b>SANDERS</b>	<b>23-26</b>
SI-3100/SI-3100M	23
SI-3101/SI-3101M	23
SI-3111/SI-3111M	23
SI-3101-6/SI-3101-6M	23
SI-3111-6/SI-3111-6M	23
SI-3103A/SI-3103AM	24
SI-3113A/SI-3113AM	24
SI-3103-6A/SI-3103-6AM	24
SI-3113-6A/SI-3113-6AM	24
SI-3105/SI-3105M	24
SI-3105-6/SI-3105-6M	24
SI-3118/SI-3118M	25
SI-3118-6	25
SI-3005	25
SI-3007/SI-3007M	25
SI-3115R	25
SI-3115R-6	25
SI-3001A/SI-3001AM	26
SI-3011A/SI-3011AM	26
SI-3003A/SI-3003AM	26
SI-3013A/SI-3013AM	26

## SANDERS

33-35

## POLISHERS

36-39

## GRINDERS

SI-3018/SI-3018M	26
<b>MINI SANDERS</b>	<b>27-28</b>
SI-3102/SI-3102M	27
SI-3112/SI-3112M	27
SI-2007A	27
SI-2008	27
SI-2107A	27
SI-2108	27
SI-2110	28
<b>DISC SANDERS</b>	<b>28-29</b>
SI-2202	28
SI-2201	28
SI-2210	28
SI-2300	28
SI-2026	29
SI-2351	29
<b>OSCILLATION SANDERS</b>	<b>29</b>
SI-3200A	29
SI-3300	29
<b>WET SANDERS</b>	<b>29</b>
SI-2322WR	29
SI-2322WR-E	29
ACCESSORIES	30-32

## POLISHERS

<b>GEARED DUAL ACTION POLISHERS</b>	<b>34</b>
SI-2415	34
<b>DUAL ACTION POLISHERS</b>	<b>34</b>
SI-3100P	34
<b>SINGLE ACTION POLISHERS</b>	<b>34-35</b>
SI-2221	34
SI-2400	34
SI-2405	34
SI-2451	34
SI-2009	35
SI-2009H	35
ACCESSORIES	35

## GRINDERS

<b>DIE GRINDERS</b>	<b>37-38</b>
SI-2001S/SI-2001S-6	37
SI-2002/SI-2002-6	37
SI-2006S/SI-2006S-6	37
SI-2005/SI-2005-6	37
SI-2011S/SI-2011S-6	37
SI-2012/SI-2012-6	37
SI-2015A/SI-2015A-6	38
SI-2010/SI-2010-6	38
SI-2022S/SI-2022S-6	38
SI-2023/SI-2023-6	38
<b>CUT OFF GRINDERS</b>	<b>38</b>
SI-2033	38
<b>DISC GRINDERS</b>	<b>38-39</b>
SI-2501L/SI-2501	38
SI-2500L/SI-2500	39
SI-2515LA	39
SI-2505L	39
SI-2600L	39
<b>MICRO GRINDERS</b>	<b>39</b>
SI-2050AG	39
SI-2051SG	39

40-43

## DRILLS / SPOTMILLS

44-46

## CUTTING TOOLS

## OTHERS

50

51

52-54

## DRILLS/ SPOTMILLS

<b>DRILLS</b>	<b>41-42</b>
SI-2015AD	41
SI-5100A	41
SI-5200A	41
SI-5300A	41
SI-5305A	41
SI-5305-8A	41
SI-5501	42
SI-5506	42
SI-5500	42
SI-5505	42
SI-5355	42
<b>SPOT MILLS</b>	<b>42</b>
SI-5800	42
SI-5850A	42
ACCESSORIES	43

## CUTTING TOOLS

<b>SAWS</b>	<b>45</b>
SI-4700B	45
SI-4710/SI-4710F	45
SI-4730	45
OSCILLATION CUTTER	45
SI-4300	45
<b>NIBBLER</b>	<b>45</b>
SI-4600	45
<b>SHEAR</b>	<b>45</b>
SI-4500	45
<b>TRIMMER</b>	<b>46</b>
SI-2018A	46
ACCESSORIES	46

## OTHERS

<b>AIR HAMMER</b>	<b>48</b>
SI-4120A	48
AIR HAMMERS ACCESSORIES	48
<b>NEEDLE SCALER</b>	<b>49</b>
SI-4150	49
<b>HYDRO PUNCHER</b>	<b>49</b>
SI-4800	49
OTHERS ACCESSORIES	49

## MAINTENANCE CHECK

## QUALITY

## ACCESSORIES



# IMPACT WRENCHES

## IMPACT WRENCHES / 1/4" IMPACT WRENCHES • 3/8" IMPACT WRENCHES

### NEW SI-1310 1/4" Impact Wrench

- Maximum Torque : 40Nm
- Composite body absorbs the vibration remarkably well and also protects your hand from the cold.
- Compact, lightweight, and a "feather touch" trigger for easy operation.
- Rear exhaust from handle-end directs air away from operator and workplace.

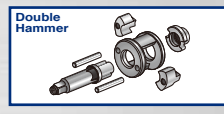
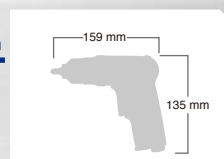

### SI-1301 3/8" Impact Wrench

- Maximum Torque: 70Nm
- A palm grip body with a butterfly throttle lever gives you quick and easy one-hand operation
- Heavy-duty double hammer clutch for industrial use

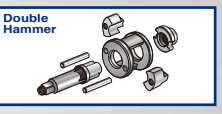
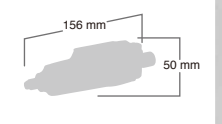

### SI-1305 3/8" Impact Wrench

- Maximum Torque: 90Nm
- 3/8" sq. palm grip Impact with butterfly throttle lever for quick and easy single hand operation
- 360° Air inlet swivel for easy manoeuvring

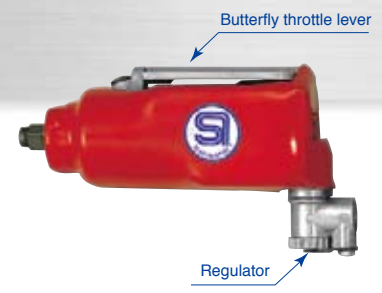
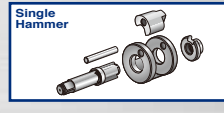
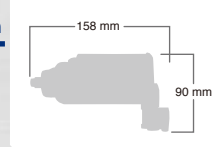

### NEW SI-1315 3/8" Impact Wrench

- Maximum Torque : 60Nm
- Composite body absorbs the vibration remarkably well and also protects your hand from the cold.
- Compact, lightweight, and a "feather touch" trigger for easy operation.
- Rear exhaust from handle-end directs air away from operator and workplace.

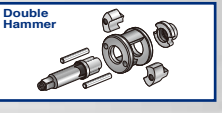
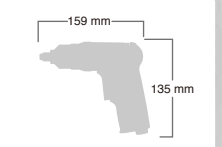

### SI-1355 3/8" Impact Wrench

- Maximum Torque: 90Nm
- Standard impact wrench with front exhaust
- Push button action for reverse

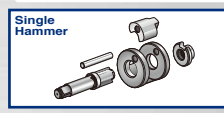
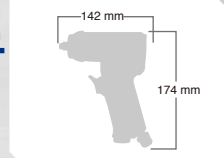

Model Number	Maximum Torque Nm/(ft-lb)	Working Torque Range Nm/(ft-lb)	Bolt Cap mm/(in.)	Free Speed rpm	Weight kg/(lb)	Over Length mm/(in.)	Noise Level dBA/ (power)	Vibration m/s <sup>2</sup>	Avg. Air Consumption CFM	Air Inlet Size in.	Hose Size mm/(in.)	Clutch Type
SI-1310	40/(30)	0-35/(0-26)	8/(5/16)	10,000	0.63/(1.39)	159/(6.26)	82/(95)	< 2.5	2.1	1/4	10/(3/8)	Double Hammer
SI-1301	70/(52)	0-65/(0-48)	10/(3/8)	10,000	0.65/(1.43)	156/(6.14)	98/(110)	5.3	2.6	1/4	10/(3/8)	Double Hammer
SI-1305	90/(66)	0-75/(0-55)	10/(3/8)	10,000	0.94/(2.08)	158/(6.20)	98/(111)	7.4	2.8	1/4	10/(3/8)	Single Hammer
SI-1315	60/(44)	0-50/(0-37)	10/(3/8)	10,000	0.63/(1.39)	159/(6.26)	82/(95)	< 2.5	2.1	1/4	10/(3/8)	Double Hammer
SI-1355	90/(66)	0-75/(0-55)	10/(3/8)	9,000	1.12/(2.47)	142/(5.57)	89/(102)	3.1	2.7	1/4	10/(3/8)	Single Hammer

IMPACT WRENCHES  
DRIVERS  
RATCHET WRENCHES  
SANDERS  
POLISHER  
GRINDERS  
DRILLS/SPOTMILLS  
CUTTING TOOLS  
OTHERS  
MAINTENANCE CHECK  
QUALITY  
ACCESSORIES



# IMPACT WRENCHES / 3/8" IMPACT WRENCHES • 1/2" IMPACT WRENCHES

★ : Attachment Included  
☆ : Accessories

## SI-1356 3/8" Impact Wrench

- Maximum Torque:180Nm
- A one piece polymer body combined with a pin clutch
- Compact and light weight with high torque



## SI-1365 3/8" Impact Wrench

- Maximum Torque:100Nm
- The ultimate design for a 3/8" sq drive impact wrench
- Precision machined air motor for durability
- Muffled exhaust for industrial use

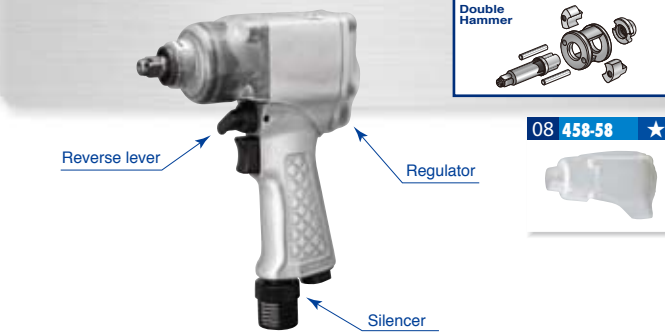

## SI-1370 3/8" Impact Wrench

- Maximum Torque:100Nm
- Heavy-duty double hammer clutch for industrial use
- Straight shape body
- Precision machined air motor for long tool life

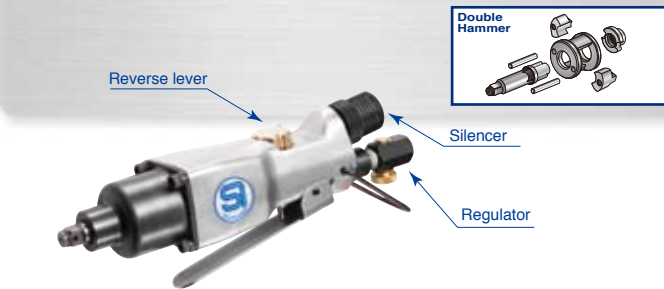

## SI-1456 1/2" Impact Wrench

- Maximum Torque:220Nm
- Features a one piece polymer body and newly designed pin clutch for light weight and high torque
- Compact design for narrow space



## SI-1650AH 1/2" Impact Wrench

- Maximum Torque:350Nm
- 90°head model
- Possible to turn the head 360°
- Ideal for changing the blade of tractors and farming equipment



# 1/2" IMPACT WRENCHES

NEW

## SI-1610 1/2" Impact Wrench

- Maximum Torque : 450Nm
- Rubber grip absorbs the vibration remarkably well and also protects your hand from the cold.
- Ergonomic design, compact, and lightweight for easy operation.
- Muffler reduces noise level.



NEW

## SI-1610SR 1/2" Impact Wrench

- Maximum Torque : 450Nm
- Rubber grip absorbs the vibration remarkably well and also protects your hand from the cold.
- Ergonomic design, compact, and lightweight for easy operation.
- Full power in reverse helps to unfasten bolts quickly for changing wheels



## SI-1420T 1/2" Impact Wrench

- Maximum Torque:500Nm
- Higher powered impact wrench with 1/2"sq. anvil
- The double hammer clutch delivers higher torque and faster power delivery

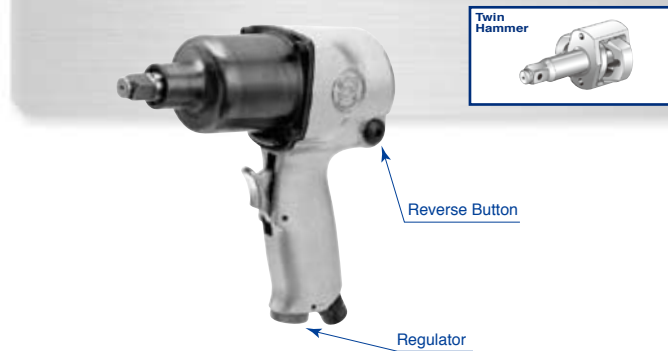

## SI-1422T 1/2" Impact Wrench

- Maximum Torque:480Nm
- The same quality features of SI-1432T with 2" extended anvil

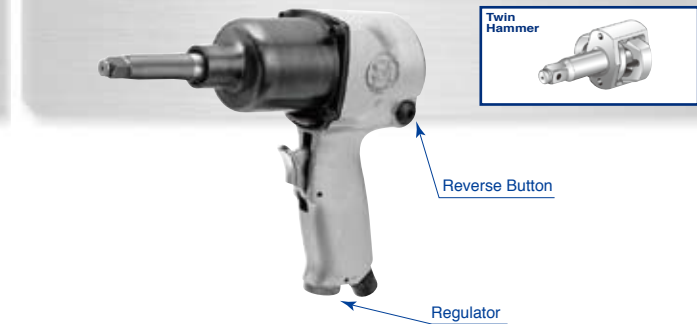

## SI-1440T 1/2" Impact Wrench

- Maximum Torque:850Nm
- Solid composite body
- Single lever controller for the air regulation and the reverse function
- Full reverse air regulation system.
- Twin hammer clutch makes a big torque



## SI-1442T 1/2" Impact Wrench

- Maximum Torque:800Nm
- The long anvil type of SI-1440T
- 2" extended anvil gives you easy operation at the narrow place



Model Number	Maximum Torque Nm/(ft-lb)	Working Torque Range Nm/(ft-lb)	Bolt Cap mm/(in.)	Free Speed rpm	Weight kg/(lb)	Over Length mm/(in.)	Noise Level dBA/(power)	Vibration m/s <sup>2</sup>	Avg. Air Consumption CFM	Air Inlet Size in.	Hose Size mm/(in.)	Clutch Type
SI-1356	180/(133)	0-150/(0-111)	10/(3/8)	8,000	1.10/(2.43)	165/(6.50)	84/(97)	3.3	3.6	1/4	10/(3/8)	Pin Clutch
SI-1365	100/(74)	0-80/(0-59)	10/(3/8)	9,000	1.31/(2.89)	134/(5.28)	83/(96)	3.3	3.3	1/4	10/(3/8)	Double Hammer
SI-1370	100/(74)	0-85/(0-63)	10/(3/8)	9,000	1.18/(2.61)	219/(8.60)	85/(97)	3.8	4.3	1/4	10/(3/8)	Double Hammer
SI-1456	220/(162)	0-180/(0-133)	16/(5/8)	8,000	1.13/(2.49)	168/(6.61)	84/(97)	4.3	3.6	1/4	10/(3/8)	Pin Clutch
SI-1650AH	350/(258)	0-280/(0-207)	16/(5/8)	(F)7,500 (R)8,000	2.80/(6.17)	270/(10.6)	83/(96)	9.4	4.0	1/4	10/(3/8)	Twin Hammer

Model Number	Maximum Torque Nm/(ft-lb)	Working Torque Range Nm/(ft-lb)	Bolt Cap mm/(in.)	Free Speed rpm	Weight kg/(lb)	Over Length mm/(in.)	Noise Level dBA/(power)	Vibration m/s <sup>2</sup>	Avg. Air Consumption CFM	Air Inlet Size in.	Hose Size mm/(in.)	Clutch Type
SI-1610	450/(332)	0-320/(0-258)	16/(5/8)	(F)8,000 (R)8,500	1.04/(2.29)	148/(5.83)	89/(102)	4.0	3.8	1/4	10/(3/8)	Twin Hammer
SI-1610SR	450/(332)	0-320/(0-258)	16/(5/8)	(F)8,000 (R)8,500	1.04/(2.29)	148/(5.83)	89/(102)	4.0	3.8	1/4	10/(3/8)	Twin Hammer
SI-1420T	500/(369)	0-400/(0-295)	16/(5/8)	6,000	2.55/(5.62)	191/(7.52)	96/(108)	3.2	4.0	1/4	10/(3/8)	Twin Hammer
SI-1422T	480/(354)	0-360/(0-266)	16/(5/8)	6,000	2.64/(5.82)	225/(8.86)	96/(108)	3.8	4.0	1/4	10/(3/8)	Twin Hammer
SI-1440T	850/(627)	0-620/(0-457)	18/(11/16)	(F)8,000 (R)9,000	2.12/(4.66)	188/(7.40)	95/(105)	4.0	4.8	1/4	10/(3/8)	Twin Hammer
SI-1442T	800/(590)	0-600/(0-443)	18/(11/16)	(F)8,000 (R)9,000	2.22/(4.88)	240/(9.45)	95/(105)	4.2	4.8	1/4	10/(3/8)	Twin Hammer

IMPACT WRENCHES  
DRIVERS  
RATCHET WRENCHES  
SANDERS  
POLISHER  
GRINDERS  
DRILLS/SPOTMILLS  
CUTTING TOOLS  
OTHERS  
MAINTENANCE CHECK  
QUALITY



**SI-1480A** 1/2" Impact Wrench

- Maximum Torque:800Nm
- Solid composite body
- Oil bath pin clutch system produces big torque and reduced vibration
- A smooth operating tool with low user fatigue
- One hand operation reverse lever
- "Feather touch" T valve trigger for easy operation

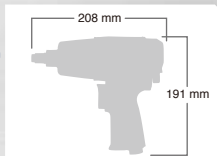

**SI-1482A** 1/2" Impact Wrench

- Maximum Torque:780Nm
- The same quality features of SI-1480SR with 2" extended anvil

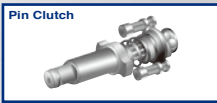
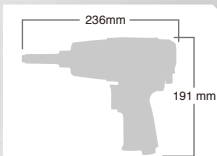

**SI-1480ASR** 1/2" Impact Wrench

- Maximum Torque:800Nm
- Aluminum housing makes for a lighter weight than SI-1480SR
- Includes a specially designed, forward-reverse system for tire work
- Full power in reverse helps to unfasten bolts quickly for a quick wheel change
- One hand operation reverse lever
- Feather touch T valve trigger for easy operation

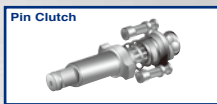
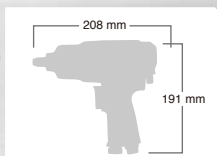

**SI-1482ASR** 1/2" Impact Wrench

- Maximum Torque:800Nm
- The same quality features of SI-1480SR with 2" extended anvil

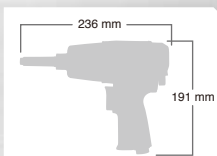

**SI-1540B** 3/4" Impact Wrench

- Maximum Torque:2,000Nm
- Lightweight of 3.4kg and compact size for minimum operator fatigue.
- Maximum Torque of 2000Nm over for every heavy bolt applications.

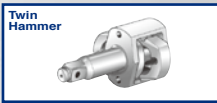
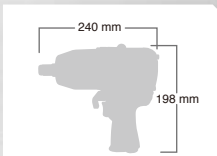

**SI-1546B** 3/4" Impact Wrench

- Maximum Torque:1,900Nm
- 6" extended anvil for SI-1540T

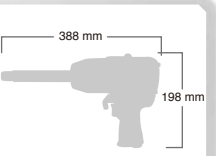

**SI-1540BSR** 3/4" Impact Wrench

- Maximum Torque:2,000Nm
- Lightweight of 3.4kg and compact size for minimum operator fatigue.
- Maximum Torque of 2000Nm over for every heavy bolt applications.
- Full power in reverse helps to unfasten bolts quickly for a quick wheel change

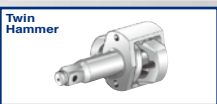
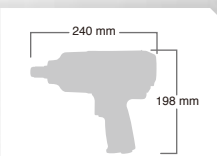

**SI-1546BSR** 3/4" Impact Wrench

- Maximum Torque:1,900Nm
- 6" extended anvil for SI-1540T
- Full power in reverse helps to unfasten bolts quickly for a quick wheel change

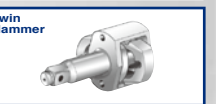
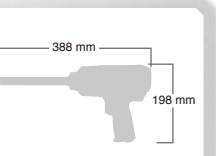

Model Number	Maximum Torque Nm/ (ft-lb)	Working Torque Range Nm/ (ft-lb)	Bolt Cap mm/ (in.)	Free Speed rpm	Weight kg/ (lb)	Over Length mm/ (in.)	Noise Level dBA/ (power)	Vibration m/s <sup>2</sup>	Avg. Air Consumption CFM	Air Inlet Size in.	Hose Size mm/ (in.)	Clutch Type
SI-1480A	800/(590)	0-600/(0-443)	18/(11/16)	(F)7,000 (R)8,000	2.07/(4.56)	208/(8.19)	95/(108)	3.1	5.8	1/4	10/(3/8)	Pin Clutch
SI-1482A	780/(575)	0-580/(0-428)	18/(11/16)	(F)7,000 (R)8,000	2.11/(4.65)	236/(9.29)	95/(108)	4.1	5.8	1/4	10/(3/8)	Pin Clutch
SI-1480ASR	800/(590)	0-600/(0-443)	18/(11/16)	(F)7,000 (R)8,000	2.07/(4.56)	208/(8.19)	95/(108)	3.1	5.8	1/4	10/(3/8)	Pin Clutch
SI-1482ASR	780/(575)	0-580/(0-428)	18/(11/16)	(F)7,000 (R)8,000	2.11/(4.65)	236/(9.29)	95/(108)	4.1	5.8	1/4	10/(3/8)	Pin Clutch

Model Number	Maximum Torque Nm/ (ft-lb)	Working Torque Range Nm/ (ft-lb)	Bolt Cap mm/ (in.)	Free Speed rpm	Weight kg/ (lb)	Over Length mm/ (in.)	Noise Level dBA/ (power)	Vibration m/s <sup>2</sup>	Avg. Air Consumption CFM	Air Inlet Size in.	Hose Size mm/ (in.)	Clutch Type
SI-1540B	2,000/(1,475)	0-1,200/(0-885)	20/(3/4)	(F)6,500 (R)7,000	3.40/(7.50)	240/(9.45)	95/(108)	8.0	9.0	3/8	13/(1/2)	Twin Hammer
SI-1546B	1,900/(1,401)	0-1,100/(0-811)	20/(3/4)	(F)6,500 (R)7,000	4.10/(9.04)	388/(15.3)	95/(108)	9.0	9.0	3/8	13/(1/2)	Twin Hammer
SI-1540BSR	2,000/(1,475)	0-1,200/(0-885)	20/(3/4)	(F)6,500 (R)7,000	3.40/(7.50)	240/(9.45)	95/(108)	8.0	9.0	3/8	13/(1/2)	Twin Hammer
SI-1546BSR	1,900/(1,401)	0-1,100/(0-811)	20/(3/4)	(F)6,500 (R)7,000	4.10/(9.04)	388/(15.3)	95/(108)	9.0	9.0	3/8	13/(1/2)	Twin Hammer



## SI-1700 1" Impact Wrench

- Maximum Torque: 2,000Nm
- Light weight straight shape body impact wrench with 1" sq. anvil
- Pin clutch system makes a big torque and low vibration

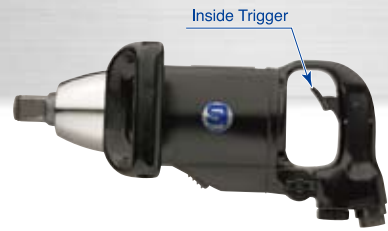
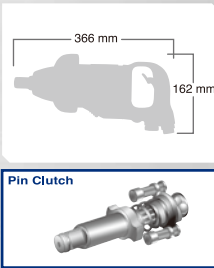

## SI-1706 1" Impact Wrench

- Maximum Torque: 1,900Nm
- 6" extended anvil for SI-1700

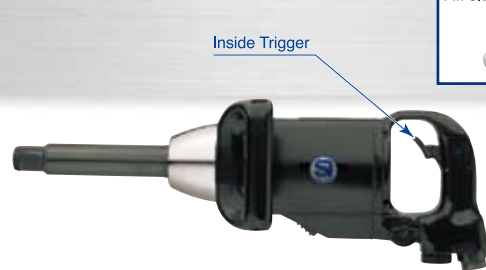
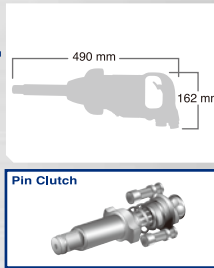

## SI-1710 1" Impact Wrench

- Maximum Torque: 1,760Nm
- Light weight pistol grip impact wrench with 1" sq. anvil.
- Pin clutch system makes a big torque and low vibration
- With : Dead handle

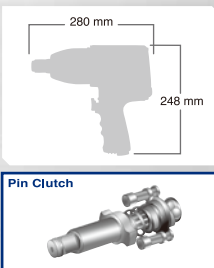

## SI-1760T 1" Impact Wrench

- Maximum Torque: 2,200Nm
- Pistol grip impact wrench with 1" sq. anvil
- A newly designed impact wrench featuring a compact body and powerful twin hammer clutch
- The twin hammer clutch delivers higher torque and quick response

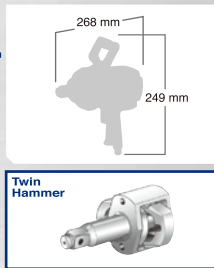

## SI-1766T 1" Impact Wrench

- Maximum Torque: 2,160Nm
- The same quality features of SI-1760T with 6" extended anvil
- Reach into deep truck wheels easily

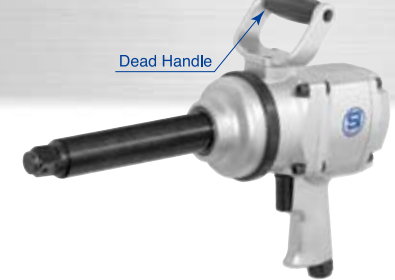
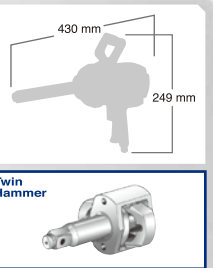

## SI-1770T 1" Impact Wrench

- Maximum Torque: 2,300Nm
- Straight body impact wrench with 1" sq. anvil and D handle
- The twin hammer clutch delivers higher torque and fast power delivery
- Compact body design for reduced weight

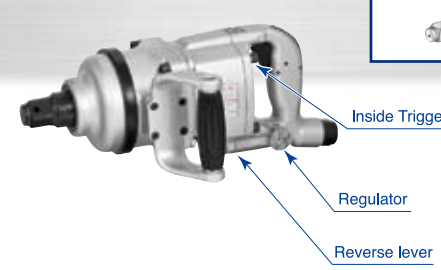
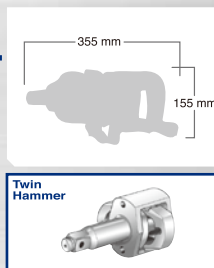

## SI-1776T 1" Impact Wrench

- Maximum Torque: 2,200Nm
- The same quality features of SI-1770T with 6" extended anvil

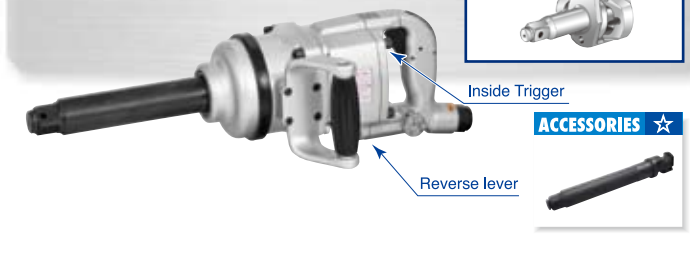
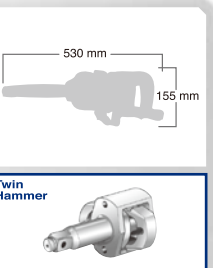

## SI-1850B 1" Impact Wrench

- Maximum Torque: 1,600Nm
- Straight body impact wrench with 1" sq. anvil and D handle
- Original model with a single hammer clutch for reliability
- 38mm Capacity

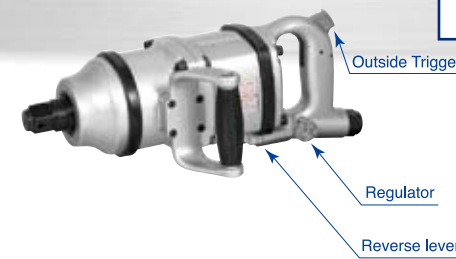
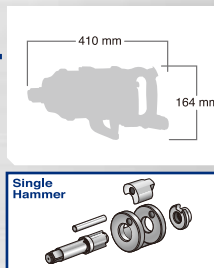

## SI-1856B 1" Impact Wrench

- Maximum Torque: 1,500Nm
- The same quality features of SI-1850B with 6" extended anvil

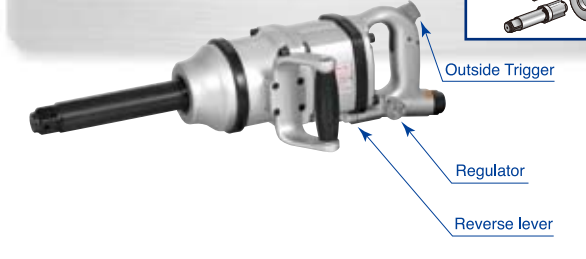
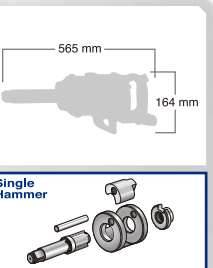

Model Number	Maximum Torque Nm/(ft-lb)	Working Torque Range Nm/(ft-lb)	Bolt Cap mm/(in.)	Free Speed rpm	Weight kg/(lb)	Over Length mm/(in.)	Noise Level dBA/(power)	Vibration m/s <sup>2</sup>	Avg. Air Consumption CFM	Air Inlet Size in.	Hose Size mm/(in.)	Clutch Type
SI-1700	2,000/(1,480)	0-1,600/(0-1,180)	38/(1-1/2)	(F)4,500 (R)5,000	7.40/(16.3)	366/(14.4)	101/(114)	7.0	10.5	1/2	13/(1/2)	Pin Clutch
SI-1706	1,900/(1,400)	0-1,500/(0-1,110)	38/(1-1/2)	(F)4,500 (R)5,000	8.40/(18.5)	490/(19.3)	101/(114)	7.3	10.5	1/2	13/(1/2)	Pin Clutch
SI-1710	1,760/(1,300)	0-1,300/(0-959)	38/(1-1/2)	(F)3,600 (R)4,200	7.60/(16.8)	280/(11.0)	102/(116)	5.2	7.7	1/2	13/(1/2)	Pin Clutch

Model Number	Maximum Torque Nm/(ft-lb)	Working Torque Range Nm/(ft-lb)	Bolt Cap mm/(in.)	Free Speed rpm	Weight kg/(lb)	Over Length mm/(in.)	Noise Level dBA/(power)	Vibration m/s <sup>2</sup>	Avg. Air Consumption CFM	Air Inlet Size in.	Hose Size mm/(in.)	Clutch Type
SI-1760T	2,200/(1,620)	0-1,650/(0-1,220)	38/(1-1/2)	5,000	8.13/(17.9)	268/(10.6)	101/(114)	7.6	13.3	1/2	13/(1/2)	Twin Hammer
SI-1766T	2,160/(1,590)	0-1,600/(0-1,180)	38/(1-1/2)	5,000	8.56/(18.8)	430/(16.9)	101/(114)	8.4	13.3	1/2	13/(1/2)	Twin Hammer
SI-1770T	2,300/(1,700)	0-1,700/(0-1,250)	38/(1-1/2)	5,000	8.44/(18.6)	355/(14.0)	100/(113)	8.6	12.3	1/2	13/(1/2)	Twin Hammer
SI-1776T	2,200/(1,620)	0-1,650/(0-1,220)	38/(1-1/2)	5,000	8.87/(19.6)	530/(20.9)	100/(113)	8.8	12.3	1/2	13/(1/2)	Twin Hammer
SI-1850B	1,600/(1,180)	0-1,400/(0-1,030)	38/(1-1/2)	4,000	10.9/(24.0)	410/(16.1)	102/(114)	6.2	14.0	1/2	13/(1/2)	Single Hammer
SI-1856B	1,500/(1,110)	0-1,200/(0-885)	38/(1-1/2)	4,000	12.3/(27.1)	565/(22.2)	102/(114)	7.6	13.7	1/2	13/(1/2)	Single Hammer



**103-1**

Muffler



01

**911P-25**

Muffler



02

**215RA-15**

Muffler with Filter inside  
(quieter than 911P-25)



03

**911A-15**

Muffler Retainer



04

**736-8**

Muffler Retainer



05

**911P-11**

Retainer



06

**736DH-10**

Retainer



07

**458-58**

Housing Cover



08

**EXPLANATION OF CLUTCH**

**Single Hammer**

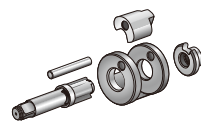

One hammer makes one impact per rotation. This means greater hitting power, long life and easy maintenance.

**Double Hammer**

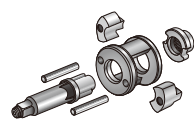

Two hammers make two impacts per rotation. Two hammers of the same form as a single hammer are held. There is little vibration and high torque is obtained than single hammer.

**Twin Hammer**

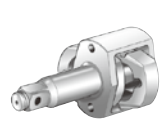

Two hammers make one impact per rotation. This design is the most durable of hammer designs and lighter, less vibration, producing a powerful impact.

**Roller Clutch**

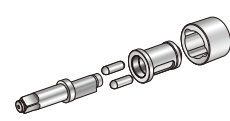

One hammer makes one impact per rotation. It has the characteristic of a single hammer that produce a high torque per one impact and has the characteristics of the double hammer of the numerousness impacts per minute.

**Pin Clutch**

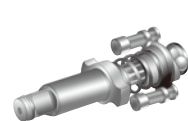

One hammer makes one impact per rotation. Rotating mechanism in which the round hammer pins move up and down, engaging the anvil and producing a powerful impact. It produce higher torque with minimum vibration.

**DRIVERS**



**SI-1052** Impact Driver

- More powerful than SI-1051
- Have regulator built-in
- Compact body design for reduce weight and easy operation

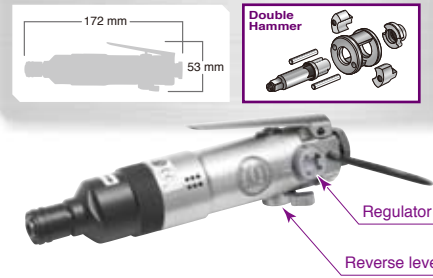

**SI-1060** Impact Driver

- 6mm capacity straight grip impact driver
- Compact, lightweight, ergonomic design for easy operation
- General use

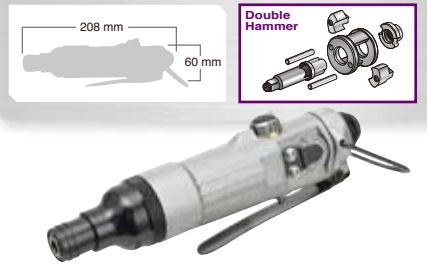

**SI-1062** Impact Driver

- More powerful than SI-1061
- Built-in regulator
- Compact body design for reduce weight and easy operation

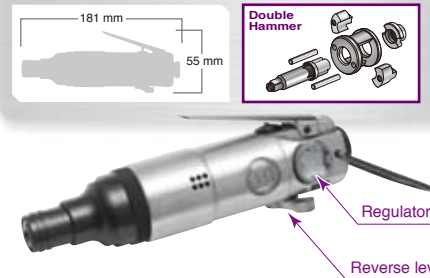

**SI-1065** Impact Driver

- 6mm capacity pistol grip impact driver
- General use
- Ergonomic pistol grip for easy operation



**NEW**  
**SI-1070** Impact Driver

- 6mm capacity pistol grip impact driver
- General use
- Compact, lightweight and a "feather touch" trigger for easy operation.



**SI-1301D** Impact Driver

- A palm grip body with the butterfly throttle lever
- Heavy-duty double hammer clutch for industrial use



**SI-1356D** Impact Driver

- 8mm capacity pistol grip impact driver
- Double hammer mechanism



**SI-1365D** Impact Driver

- 8mm capacity pistol grip impact driver
- Industrial use

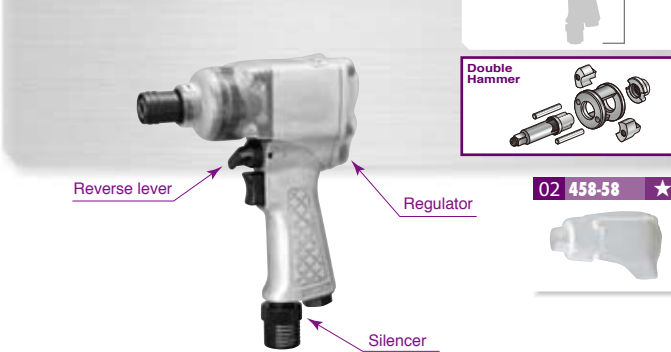

**SI-1370D** Impact Driver

- 8mm capacity straight grip impact driver
- Industrial use
- Precision parts for increased durability
- High quality air motor for less vibration

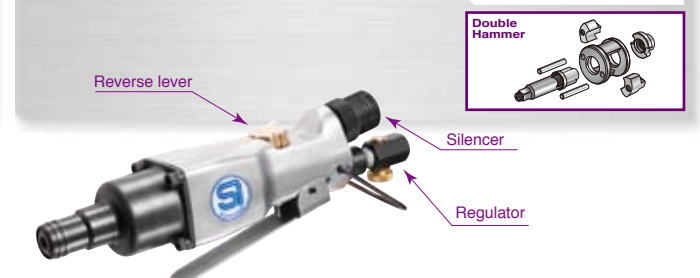

**SI-1140** Screw Driver

- 4mm capacity straight grip screw driver
- Clutch mechanism for easy adjustment of maximum torque



**SI-1161** Screw Driver

- 6mm capacity straight grip screw driver
- Adjustable clutch
- Compact, lightweight, and ergonomic design for easy operation



**SI-1166A** Screw Driver

- 6mm capacity pistol grip screw driver
- Adjustable clutch
- Ergonomic pistol grip for easy operation



**SI-1166-8A** Screw Driver

- 8mm capacity pistol grip screw driver
- Adjustable clutch
- Ergonomic pistol grip for easy operation



**NEW**  
**SI-1170** Screw Driver

- An adjustment ring with easy torque adjustment
- The full composite tool of an original design
- An oscillation is eased by a soft grip



Model Number	Shank Size in./mm	Max Torque Nm/(ft-lb)	Working Torque Nm/(ft-lb)	Bolt Cap mm/(in.)	Free Speed rpm	Weight kg/(lb)	Noise Level dBA/(power)	Vibration m/s <sup>2</sup>	Avg. Air Consumption CFM	Air Inlet Size in.	Hose Size mm/(in.)	Clutch Type
SI-1052	1/4/(6.35)	70/(51.6)	0-60/(0-44)	5/(3/16)	13,000	0.56/(1.23)	91/(104)	4.1	2.3	1/4	10/(3/8)	Double Hammer
SI-1060	1/4/(6.35)	65/(47.9)	0-50/(0-37)	6/(1/4)	11,000	0.87/(1.92)	92/(104)	4.0	2.9	1/4	10/(3/8)	Double Hammer
SI-1062	1/4/(6.35)	95/(70.1)	0-70/(0-52)	6/(1/4)	11,000	0.79/(1.74)	91/(104)	4.0	2.8	1/4	10/(3/8)	Double Hammer
SI-1065	1/4/(6.35)	65/(47.9)	0-45/(0-33)	6/(1/4)	11,000	0.98/(2.16)	94/(107)	5.0	3.4	1/4	10/(3/8)	Double Hammer
SI-1070	1/4/(6.35)	35/(25.8)	0-30/(0-22)	6/(1/4)	11,000	0.37/(0.81)	82/(95)	< 2.5	2.1	1/4	10/(3/8)	Double Hammer
SI-1301D	1/4/(6.35)	55/(40.6)	0-45/(0-33)	6/(1/4)	9,500	0.68/(1.49)	98/(110)	4.8	2.6	1/4	10/(3/8)	Double Hammer
SI-1356D	1/4/(6.35)	55/(40.6)	0-45/(0-33)	8/(5/16)	9,000	1.22/(2.69)	89/(102)	3.3	2.7	1/4	10/(3/8)	Double Hammer

Model Number	Shank Size in./mm	Max Torque Nm/(ft-lb)	Working Torque Nm/(ft-lb)	Bolt Cap mm/(in.)	Free Speed rpm	Weight kg/(lb)	Noise Level dBA/(power)	Vibration m/s <sup>2</sup>	Avg. Air Consumption CFM	Air Inlet Size in.	Hose Size mm/(in.)	Clutch Type
SI-1365D	1/4/(6.35)	70/(51.6)	0-60/(0-44)	8/(5/16)	8,000	1.32/(2.92)	83/(96)	3.3	3.3	1/4	10/(3/8)	Double Hammer
SI-1370D	1/4/(6.35)	80/(59.0)	0-65/(0-48)	8/(5/16)	9,000	1.21/(2.66)	85/(97)	3.6	4.3	1/4	10/(3/8)	Double Hammer
SI-1140	1/4/(6.35)	1.5/(1.1)	0.3-1.5/(0.2-1.1)	4/(5/32)	1,700	0.62/(1.36)	84/(96)	4.5	1.9	1/4	10/(3/8)	Cushion Type
SI-1161	1/4/(6.35)	5.0/(3.7)	1.5-5.0/(1.1-3.7)	6/(1/4)	1,600	1.12/(2.46)	91/(104)	< 2.5	2.8	1/4	10/(3/8)	Cushion Type
SI-1166A	1/4/(6.35)	5.0/(3.7)	1.5-5.0/(1.1-3.7)	6/(1/4)	2,000	1.18/(2.60)	94/(107)	< 2.5	3.5	1/4	10/(3/8)	Cushion Type
SI-1166-8A	1/4/(6.35)	9.0/(6.6)	1.5-5.0/(1.1-3.7)	8/(5/16)	800	1.35/(2.97)	95/(108)	< 2.5	3.3	1/4	10/(3/8)	Cushion Type
SI-1170	1/4/(6.35)	20/(14.8)	4-11/(2.9-8.1)	8/(5/16)	550	0.85/(1.87)	83/(96)	4.0	2.3	1/4	10/(3/8)	Cushion Type



# RATCHET WRENCHES

## RATCHET WRENCHES / 1/4" RATCHET WRENCHES • 3/8" RATCHET WRENCHES

### SI-1107B 1/4" Ratchet Wrench

- Maximum Torque: 30Nm
- Super small ratchet wrench with 1/4" sq. anvil
- Smaller than SI-1200B & SI-1205B

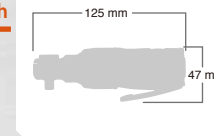

### SI-1200B 1/4" Ratchet Wrench

- Maximum Torque: 35Nm
- Light and small ratchet wrench with 1/4" sq. anvil
- This model is the "Mini Ratchet Wrench" standard in the air tools industry

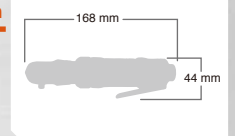

### SI-1207 1/4" Ratchet Wrench

- Maximum Torque: 38Nm
- Same body size as SI-1200B but with a plastic body cover that protects your hand from the cold
- 360° air inlet swivel

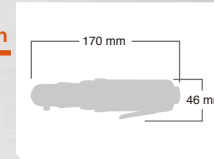

### SI-1251 1/4" Ratchet Wrench

- Maximum Torque: 45Nm
- Japan and foreign patent(s) pending as the "Slide Switch" for the reverse function
- Plastic covered small size body
- 1/4" sq. anvil

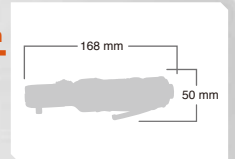

### SI-1108B 3/8" Ratchet Wrench

- Maximum Torque: 30Nm
- Super small ratchet wrench with 3/8" sq. anvil
- Smaller than SI-1200B & SI-1205B

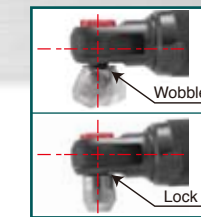
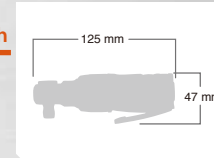

### SI-1205B 3/8" Ratchet Wrench

- Maximum Torque: 40Nm
- Light and small ratchet wrench with 3/8" sq. anvil
- This model is the "Mini Ratchet Wrench" standard in the air tools industry

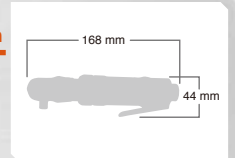

Model Number	Shank Size in./mm	Maximum Torque Nm/(ft-lb)	Working Torque Range Nm/(ft-lb)	Bolt Cap mm/(in.)	Free Speed rpm	Weight kg/(lb)	Over Length mm/(in.)	Noise Level dBA/(power)	Vibration m/s <sup>2</sup>	Avg. Air Consumption CFM	Air Inlet Size in.	Hose Size mm/(in.)
SI-1107B	1/4 / (6.35)	30/(22)	0-25/(0-18)	6.35/(1/4)	300	0.39/(0.86)	125/(4.92)	78/(91)	< 2.5	1.8	1/8	10/(3/8)
SI-1200B	1/4 / (6.35)	35/(26)	0-30/(0-22)	6.35/(1/4)	200	0.51/(1.11)	168/(6.61)	85/(97)	3.5	1.6	1/4	10/(3/8)
SI-1207	1/4 / (6.35)	38/(28)	0-30/(0-22)	6.35/(1/4)	200	0.54/(1.18)	170/(6.69)	85/(97)	3.5	1.6	1/4	10/(3/8)
SI-1251	1/4 / (6.35)	45/(33)	0-33/(0-24)	6.35/(1/4)	200	0.56/(1.24)	168/(6.61)	79/(92)	3.5	2.4	1/4	10/(3/8)
SI-1108B	3/8 / (9.5)	30/(22)	0-25/(0-18)	10/(3/8)	300	0.40/(0.88)	125/(4.92)	78/(91)	< 2.5	1.8	1/8	10/(3/8)
S-1205B	3/8 / (9.5)	40/(30)	0-30/(0-22)	10/(3/8)	220	0.51/(1.12)	168/(6.61)	86/(98)	3.5	1.6	1/4	10/(3/8)



**SI-1208** 3/8" Ratchet Wrench

- **Maximum Torque:40Nm**
- Same body size as SI-1205B but with a plastic body cover that protects your hand from the cold
- Also helps to absorb vibrations for reduced operator fatigue Built-in air
- Regulator for easy adjustment of torque

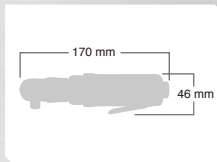

**SI-1252** 3/8" Ratchet Wrench

- **Maximum Torque:47Nm**
- Japan and foreign patent(s) pending as the "Slide Switch" for the reverse function
- Plastic covered small size body
- 3/8"sq. anvil

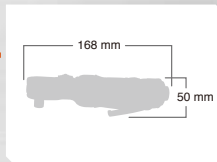

**SI-1241** 3/8" Ratchet Wrench

- Swivel head with 9 levels
- An activity is possible at the locations which cannot work in the usual spanner and/or ratchet wrenches.
- The socket lock mechanism does not drop a socket on a narrow place.

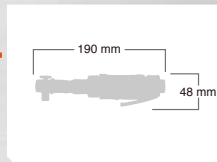

**SI-1262/1262S** 1/2" Ratchet Wrench

- **Maximum Torque:113Nm**
- Japan and foreign patent(s) pending as the "Slide Switch" for the reverse function
- Plastic covered regular size body
- The lightest 970g in this class we have ever had
- Lightweight and high strength super duralumin is used for housing

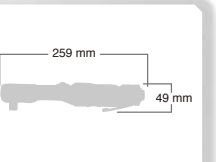

**SI-1261/1261S** 3/8" Ratchet Wrench

- **Maximum Torque:110Nm**
- Japan and foreign patent(s) pending as the "Slide Switch" for the reverse function
- Plastic covered regular size body
- The lightest 960g in this class
- Lightweight and high strength super duralumin is used for housing

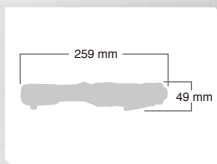

**SI-1320A** 3/8" Ratchet Wrench

- **Maximum Torque:80Nm**
- Standard ratchet wrench with the front exhaust
- 3/8"sq. anvil
- Reasonable price

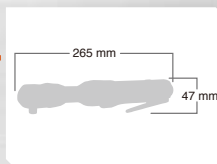

**SI-1325A** 1/2" Ratchet Wrench

- **Maximum Torque:90Nm**
- Standard ratchet wrench with the front exhaust
- 1/2"sq. anvil
- Best selling model in the world at a reasonable price

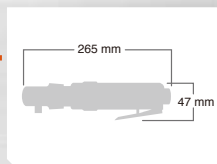

**SI-1345B** 1/2" Ratchet Wrench

- **Maximum Torque:115Nm**
- Premium quality ratchet wrench with a rear exhaust and plastic body cover
- Low noise levels and precise planetary gear mechanism
- Swivel exhaust muffler directs air away from operator and workplace
- Built-in air regulator for easy adjustment of torque
- 360° air inlet swivel

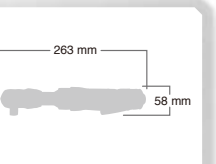

**SI-1340B** 3/8" Ratchet Wrench

- **Maximum Torque:110Nm**
- Premium quality ratchet wrench with a rear exhaust and plastic body cover
- Low noise levels and precise planetary gear mechanism assures the highest power transfer, durability and reducing vibration
- 360° air inlet swivel directs air away from operator and workplace

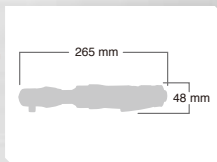

**SI-1208Q** 3/8" Ratchet Wrench

- **Maximum Torque:40Nm**
- Japan and Foreign patent(s) pending as the "Quick release function" for easily releasing sockets
- Plastic covered small size body

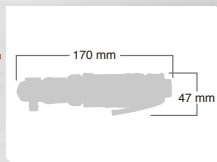

Quick release

**SI-1435** 1/2" Ratchet Wrench

- **Maximum Torque:160Nm**
- The largest ratchet wrench in the range with the highest torque
- 1/2"sq. anvil
- Good for running nuts on tractor blades

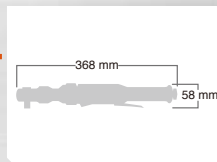

**SI-1288(s)** HEX 17mm Through

- **Maximum Torque:41Nm**
- Ratchet wrench with the unique inner sockets 8mm, 10mm, 11mm, 12mm, 13mm and 14mm of the sockets are available
- Specially designed for using in small space

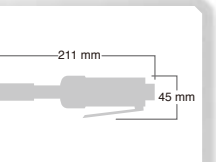

Model Number	Shank Size in./ (mm)	Maximum Torque Nm/ (ft-lb)	Working Torque Range Nm/ (ft-lb)	Bolt Cap mm/ (in.)	Free Speed rpm	Weight kg/ (lb)	Over Length mm/ (in.)	Noise Level dBA/ (power)	Vibration m/s <sup>2</sup>	Avg. Air Consumption CFM	Air Inlet Size in.	Hose Size mm/ (in.)
SI-1208	3/8 / (9.5)	40/(30)	0-30/(0-22)	10/(3/8)	200	0.54/(1.20)	170/(6.69)	86/(99)	3.5	2.2	1/4	10/(3/8)
SI-1252	3/8 / (9.5)	47/(35)	0-35/(0-26)	10/(3/8)	260	0.56/(1.24)	168/(6.61)	79/(92)	3.5	2.4	1/4	10/(3/8)
SI-1261/ SI-1261S	3/8 / (9.5)	110/(81)	0-65/(0-48)	10/(3/8)	170	1.20/(2.65)/ 0.96/(2.12)	259/(10.2)	84/(97)	7.0	3.0	1/4	10/(3/8)
SI-1320A	3/8 / (9.5)	80/(59)	0-60/(0-44)	12/(1/2)	160	1.16/(2.57)	265/(10.4)	93/(105)	7.6	2.7	1/4	10/(3/8)
SI-1340B	3/8 / (9.5)	110/(81)	0-85/(0-63)	12/(1/2)	160	1.14/(2.50)	265/(10.4)	89/(102)	7.6	2.5	1/4	10/(3/8)
SI-1208Q	3/8 / (9.5)	40/(30)	0-30/(0-22)	10/(3/8)	240	0.53/(1.17)	170/(6.69)	84/(87)	3.5	2.3	1/4	10/(3/8)

Model Number	Shank Size in./ (mm)	Maximum Torque Nm/ (ft-lb)	Working Torque Range Nm/ (ft-lb)	Bolt Cap mm/ (in.)	Free Speed rpm	Weight kg/ (lb)	Over Length mm/ (in.)	Noise Level dBA/ (power)	Vibration m/s <sup>2</sup>	Avg. Air Consumption CFM	Air Inlet Size in.	Hose Size mm/ (in.)
SI-1241	3/8 / (9.5)	30/(22.1)	0-25/(0-18.4)	10/(3/8)	250	0.63/(1.38)	190/(7.48)	89/(101)	7.6	1.9	1/4	10/(3/8)
SI-1262/ SI-1262S	1/2 / (12.7)	115/(85)	0-70/(0-52)	16/(5/8)	170	1.21/(2.67)/ 0.97/(2.14)	259/(10.2)	84/(97)	7.0	3.0	1/4	10/(3/8)
SI-1325A	1/2 / (12.7)	90/(66)	0-70/(0-52)	16/(5/8)	160	1.17/(2.58)	265/(10.4)	92/(105)	8.6	2.5	1/4	10/(3/8)
SI-1345B	1/2 / (12.7)	115/(85)	0-90/(0-66)	16/(5/8)	160	1.15/(2.53)	263/(10.4)	89/(102)	7.6	2.5	1/4	10/(3/8)
SI-1435	1/2 / (12.7)	160/(118)	0-110/(0-81)	14/(9/16)	140	1.95/(4.31)	368/(14.5)	97/(110)	9.7	4.7	1/4	10/(3/8)
SI-1288(S)	HEX 17mm	45/(33)	0-35/(0-26)	8-17/(5/16-11/16)	180	0.54/(1.20)	211/(8.31)	86/(99)	6.3	1.9	1/4	10/(3/8)



# SANDERS

## SANDERS / BELT SANDERS

★ : Attachment Included  
☆ : Accessories

### SI-2700

Belt Sander

- 10mm sanding belt sander
- Quick and easy belt change
- Adjustable arm angle

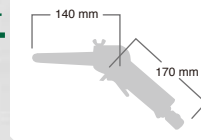

41 181-45 ☆



Attachment included

10mm Sanding belt #60x6

Accessories

- 10mm Sanding belt #40
- 10mm Sanding belt #60
- 10mm Sanding belt #80
- 10mm Sanding belt #100
- 10mm Sanding belt #120

NEW

### SI-2700L/2700LS

Belt Sander

Head rotates 120 degrees for operating convenience. Variable speed throttle for positive control.

SI-2700L

- Best for the light grinding, sanding and deburring.

SI-2700LS

- For nugget grinding of spot welding

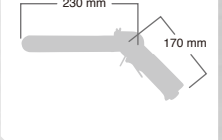

41 181-45 ☆



SI-2700L



belt 10x460mm

SI-2700LS



belt 13x460mm

### SI-2800

Belt Sander

- 20mm sanding belt sander
- Safety cover over belt wheel

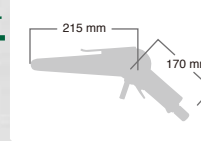

41 181-45 ☆



Attachment included

20mm Sanding belt #60x6

Accessories

- 20mm Sanding belt #40
- 20mm Sanding belt #60
- 20mm Sanding belt #80
- 20mm Sanding belt #100
- 20mm Sanding belt #120

### SI-2830

Belt Sander

- 30mm sanding belt sander
- Safety cover over belt wheel
- Side handle for firm tool control

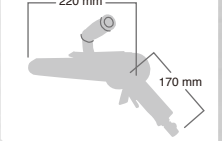

41 181-45 ☆



Attachment included

30mm Sanding belt #60x6

Accessories

- 30mm Sanding belt #40
- 30mm Sanding belt #60
- 30mm Sanding belt #80
- 30mm Sanding belt #100
- 30mm Sanding belt #120

### SI-2760

Belt Sander

- 60mm sanding belt sander
- A special tool for a mirror finish in stainless steel
- Multi function belt sander

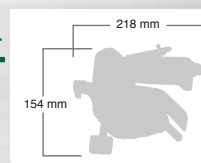

41 181-45 ☆



Attachment included

60mm Sanding belt #60x6

Accessories

- 60mm Sanding belt #40
- 60mm Sanding belt #60
- 60mm Sanding belt #80
- 60mm Sanding belt #100
- 60mm Sanding belt #120

### BELT SANDER ACCESSORIES FOR SI-2760

#### Contact wheels for sanding belt

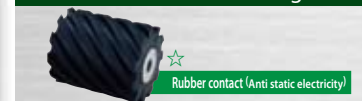

#### Sanding belts



#### Polishing equipments for mirror finish



#### Sanding equipments for hairline finish

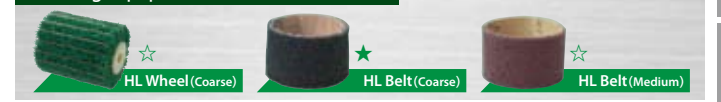



Model Number	Belt Size mm(in.)	Free Speed rpm	Out Put Watt	Weight kg/(lb)	Noise Level dBA/(power)	Vibration m/s <sup>2</sup>	Avg. Air Consumption CFM	Air Inlet Size in.	Hose Size mm/(in.)
SI-2700	10x330	15,000	317	0.82/(1.82)	90/(102)	< 2.5	3.3	1/4	10/(3/8)
SI-2700L/2700LS	10x460/13x460	15,000	317	0.85/(1.87)/0.9/(1.98)	90/(102)	< 2.5	3.3	1/4	10/(3/8)
SI-2800	20x520	15,000	429	1.43/(3.14)	90/(103)	< 2.5	3.8	1/4	10/(3/8)
SI-2830	30x540	10,000	582	2.02/(4.45)	93/(106)	< 2.5	5.3	1/4	10/(3/8)
SI-2760	—	15,000	317	1.20/(2.64)	88/(101)	< 2.5	3.4	1/4	10/(3/8)



**SI-3100** Dual Action Sander

**SI-3100M**

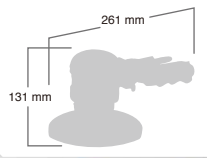
- Multi purpose dual action sander with bar grip
- 7mm orbit diameter for rough sanding
- The best and longest selling 6" random orbit model at a reasonable price

**03 486-3**   **05 M-150H**

★ SI-3100 / ☆ SI-3100M   ★ SI-3100 / ☆ SI-3100M

**SI-3101** Dual Action Sander

**SI-3101M : Velcro pad model**

- Light weight and compact palm grip body makes smooth and easy operation with 5" leather pad model
- 5" velcro pad also available 5mm orbit diameter for finish sanding
- Ergonomic, compact and lightweight design for easy operation





**03 ME-125H**   **04 PE-125H**

★ SI-3101 / ☆ SI-3101M   ★ SI-3101 / ☆ SI-3101M

**SI-3101-6** Dual Action Sander

**SI-3101-6M : Velcro pad model**

- The same quality features of SI-3101 with 6" leather pad model





**05 M-150H**   **06 P-150H**

★ SI-3101-6 / ☆ SI-3101-6M   ★ SI-3101-6 / ☆ SI-3101-6M

Model Number	Pad/Disc Size mm/(in.)	Spindle Size Female	Orbit Dia mm	Free Speed rpm	Out Put Watt	Weight kg/ (lb)	Noise Level dBA/ (power)	Vibration m/s <sup>2</sup>	Avg. Air Consumption CFM	Air Inlet Size in.	Hose Size mm/ (in.)
SI-3100/3100M	150/(6")	5/16-24UNF	7	8,000	542	1.82/(4.01)	80/(93)	5.3	2.3	1/4	10/(3/8)
SI-3101/3101M	125/(5")	5/16-24UNF	5	10,000	148	0.92/(2.03)	73/(86)	5.3	2.2	1/4	10/(3/8)
SI-3111/3111M	125/(5")	5/16-24UNF	5	9,500	148	1.27/(2.81)	88/(101)	5.7	2.3	1/4	10/(3/8)
SI-3101-6/3101-6M	150/(6")	5/16-24UNF	5	10,000	148	0.94/(2.07)	73/(86)	8.1	2.2	1/4	10/(3/8)
SI-3111-6/3111-6M	150/(6")	5/16-24UNF	5	9,500	148	1.29/(2.84)	88/(101)	5.7	2.3	1/4	10/(3/8)

**SI-3111** Dust Free Dual Action Sander

**SI-3111M : Velcro pad model**

- Dust free dual action sander
- The self generating dust system helps create a clean working environment, protecting the operator from harmful paint and filler particles
- Light weight and compact palm grip body
- 5" leather pad







**11 ME-125HD**   **12 PE-125HD**

★ SI-3111 / ☆ SI-3111M   ★ SI-3111 / ☆ SI-3111M

**SI-3111-6** Dust Free Dual Action Sander

**SI-3111-6M : Velcro pad model**

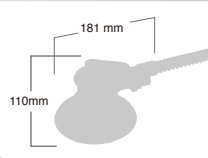
- The same quality features of SI-3116 with 9 holes 6" leather pad model

**13 M-150HD 6**   **14 P-150HD 6**

★ SI-3111-6 / ☆ SI-3111-6M   ★ SI-3111-6 / ☆ SI-3111-6M

**15 M-150HD 9**   **18 P-150HD 9**

★ SI-3111-6 / ☆ SI-3111-6M   ★ SI-3111-6 / ☆ SI-3111-6M

**NEW SI-3103A** Dual Action Sander

**SI-3103AM : Velcro pad model**

- Standard dual action sander with palm grip
- 5" pad are available
- Powerful, high quality air motor
- 5mm orbit diameter Suitable for both rough and finish sanding





**03 ME-125H**   **04 PE-125H**

★ SI-3103A / ☆ SI-3103AM   ★ SI-3103A / ☆ SI-3103AM

**NEW SI-3103-6A** Dual Action Sander

**SI-3103-6AM : Velcro pad model**

- The same quality features of SI-3103 with 6" pad model





**05 M-150H**   **06 P-150H**

★ SI-3103-6A / ☆ SI-3103-6AM   ★ SI-3103-6A / ☆ SI-3103-6AM

**SI-3105** Dual Action Sander

**SI-3105M : Velcro pad model**

- Premium quality dual action sander with bar grip
- Low vibration
- Suitable for both of light work and continuous work





**03 ME-125H**   **04 PE-125H**

★ SI-3105 / ☆ SI-3105M   ★ SI-3105 / ☆ SI-3105M

**41 181-45** ☆

Model Number	Pad/Disc Size mm/(in.)	Spindle Size Female	Orbit Dia (mm)	Free Speed rpm	Out Put Watt	Weight kg/ (lb)	Noise Level dBA/ (power)	Vibration m/s <sup>2</sup>	Avg. Air Consumption CFM	Air Inlet Size in.	Hose Size mm/ (in.)
SI-3103A/3103AM	125/(5")	5/16-24UNF	5	8,200	134	1.18/(2.60)	90/(102)	5.5	2.8	1/4	10/(3/8)
SI-3113A/3113AM	125/(5")	5/16-24UNF	5	8,000	134	1.57/(3.46)	91/(104)	6.5	2.4	1/4	10/(3/8)
SI-3103-6A/3103-6AM	150/(6")	5/16-24UNF	5	8,200	134	1.20/(2.64)	90/(102)	5.5	2.8	1/4	10/(3/8)
SI-3113-6A/3113-6AM	150/(6")	5/16-24UNF	5	8,000	134	1.59/(3.50)	91/(104)	6.5	2.4	1/4	10/(3/8)
SI-3105/3105M	125/(5")	5/16-24UNF	6	9,000	569	1.67/(3.69)	87/(99)	2.7	3.0	1/4	10/(3/8)
SI-3105-6/3105-6M	150/(6")	5/16-24UNF	6	9,000	569	1.68/(3.71)	87/(99)	4.2	3.0	1/4	10/(3/8)

**NEW SI-3113A** Dust Free Dual Action Sander

**SI-3113AM : Velcro pad model**

- Dust free dual action sander with 5" leather pad model
- The self generating dust system helps create a clean working environment, protecting the operator from harmful paint and filler particles
- Light weight and compact palm grip body





**11 ME-125HD**   **12 PE-125HD**

★ SI-3113A / ☆ SI-3113AM   ★ SI-3113A / ☆ SI-3113AM

**NEW SI-3113-6A** Dust Free Dual Action Sander

**SI-3113-6AM : Velcro pad model**

- The same quality features of SI-3113 with 9 holes 6" leather pad model





**13 M-150HD 6**   **14 P-150HD 6**

★ SI-3113-6A / ☆ SI-3113-6AM   ★ SI-3113-6A / ☆ SI-3113-6AM

**16 M-150HD 3-9**   **17 P-150HD 3-9**

★ SI-3113-6A / ☆ SI-3113-6AM   ★ SI-3113-6A / ☆ SI-3113-6AM

**SI-3105-6** Dual Action Sander

**SI-3105-6M : Velcro pad model**

- The same quality features of SI-3105 with 6" pad model





**05 M-150H**   **06 P-150H**

★ SI-3105-6 / ☆ SI-3105-6M   ★ SI-3105-6 / ☆ SI-3105-6M

**41 181-45** ☆

IMPACT WRENCHES  
DRIVERS  
RATCHET WRENCHES  
SANDERS  
POLISHER  
GRINDERS  
DRILLS/SPOTMILLS  
CUTTING TOOLS  
OTHERS  
MAINTENANCE CHECK  
QUALITY



**SI-3118** Dust Free Dual Action Sander

- SI-3118M : Velcro pad model**
- Dust free dual action sander with 5" leather pad model
  - The self generating suction system makes for a clean working environment
  - Bar grip body
  - Dust free operation protects the operator from the harmful particles of paint and filler

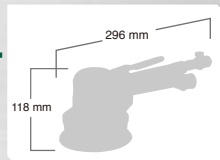

**SI-3118-6** Dust Free Dual Action Sander

- The same quality features of SI-3118 with 9 holes 6" leather pad model

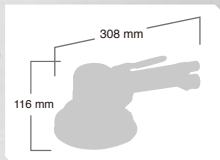

**SI-3005** Orbital Sander

- Bar grip orbital sander
- Paper size : 100mm x 180mm
- The tool has paper clips and you can use roll paper abrasive of 100mm width

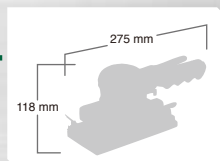

**SI-3007** Orbital Sander

- SI-3007M : Velcro pad model**
- Paper size : 100mm x 180mm
  - The tool has paper clips and you can use roll paper abrasive of 100mm width
  - One hand grip for easy operation

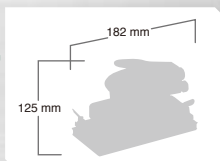

**SI-3115R** Dust Free Geared Dual Action Sander

- Geared sander with 5" Velcro pad.
- 1,000rpm low speed and high torque
- Amazing power is generated with the gear mechanism
- For heavy sanding work

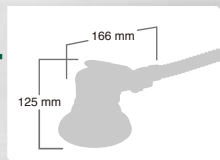

**SI-3115R-6** Dust Free Geared Dual Action Sander

- The same quality features of SI-3115 with 6" velcro pad model

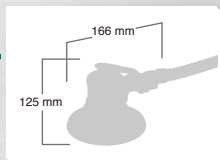

**NEW SI-3001A** Orbital Sander

- SI-3001AM : Velcro pad model**
- Light weight and compact palm grip orbital sander
  - Paper size : 75mm x 110mm

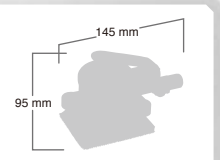

T.P.S

**NEW SI-3011A** Dust Free Orbital Sander

- SI-3011AM : Velcro pad model**
- Dust free orbital sander with palm grip and leather pad
  - Light weight and compact body
  - Paper size : 75mm x 110mm
  - Self generated suction system protects operator from harmful particles of paint and filler

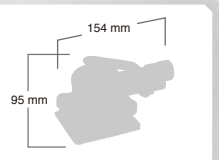

T.P.S

**NEW SI-3003A** Orbital Sander

- SI-3003AM : Velcro pad model**
- Palm grip orbital sander
  - Paper size : 75mm x 110mm
  - Powerful high quality air motor. 5mm orbit diameter

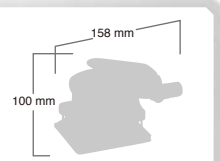

T.P.S

**NEW SI-3013A** Dust Free Orbital Sander

- SI-3013AM : Velcro pad model**
- Dust free orbital sander with palm grip and leather pad model
  - Paper size : 75mm x 110mm
  - Self generated suction system protects operator from harmful particles of paint and filler



T.P.S

**T.P.S Triple Pillar Stud System**



- Structure which the 3 pillars by a special plastic.
- It has few losses of power compared with old rubber.
- Thereby, it is excellent in durability, long life and grinding power.

**SI-3018** Dust Free Orbital Sander

- SI-3018M : Velcro pad model**
- Dust free orbital sander with bar grip
  - Paper size : 100mm x 180mm
  - With leather pad

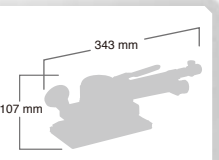

Model Number	Pad/Disc Size mm/(in.)	Spindle Size Female	Orbit Dia mm	Free Speed rpm	Out Put Watt	Weight kg/(lb)	Noise Level dBA/ (power)	Vibration m/s <sup>2</sup>	Avg. Air Consumption CFM	Air Inlet Size in.	Hose Size mm/ (in.)
SI-3118/3118M	125/(5")	5/16-24UNF	6	8,000	569	2.11/(4.65)	88/(100)	3.8	2.9	1/4	10/(3/8)
SI-3118-6	150/(6")	5/16-24UNF	6	9,500	569	2.15/(4.74)	88/(100)	3.8	2.9	1/4	10/(3/8)
SI-3005	90x165	—	4.8	8,000	289	1.87/(4.13)	92/(104)	8.5	2.3	1/4	10/(3/8)
SI-3007/3007M	95x175	—	4.8	7,500	275	1.82/(4.00)	89/(102)	9.0	2.8	1/4	10/(3/8)
SI-3115R	125/(5")	—	4.4	1,000	148	1.49/(3.27)	88/(100)	4.3	2.3	1/4	10/(3/8)
SI-3115R-6	150/(6")	—	4.4	1,000	148	1.51/(3.33)	88/(100)	4.3	2.3	1/4	10/(3/8)

Model Number	Pad/Disc Size mm/(in.)	Orbit Dia mm	Free Speed rpm	Out Put Watt	Weight kg/ (lb)	Noise Level dBA/ (power)	Vibration m/s <sup>2</sup>	Avg. Air Consumption CFM	Air Inlet Size in.	Hose Size mm/ (in.)
SI-3001A/3001AM	75x100	4	9,000	148	0.80/(1.77)	74/(86)	< 2.5	2.3	1/4	10/(3/8)
SI-3011A/3011AM	75x100	4	9,000	148	1.15/(2.53)	86/(99)	< 2.5	2.5	1/4	10/(3/8)
SI-3003A/3003AM	75x100	4	8,000	134	1.05/(2.31)	90/(102)	5.5	2.8	1/4	10/(3/8)
SI-3013A/3013AM	75x100	4	7,000	134	1.46/(3.22)	87/(100)	5.5	2.3	1/4	10/(3/8)
SI-3018/3018M	95x175	4.8	7,000	222	2.31/(5.09)	87/(100)	3.0	3.1	1/4	10/(3/8)



**SI-3102** Mini Dual Action Sander

**SI-3102M : Velcro pad model**

- Compact body design for reduce weight and easy operation
- New design for 3" pad size Mini Sander

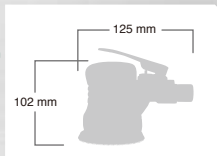

**SI-3112** Mini Dust Free Dual Action Sander

**SI-3112M : Velcro pad model**

- Compact body design for reduce weight and easy operation with
- The self generating dust system helps create a clean working
- New design for Mini Sander with 3"pad

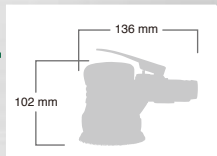

**SI-2007A** Mini Sander

- Angle head sander with 2" disc. Light and compact. It is useful for sanding and polishing work at the narrow place

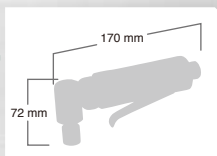

**SI-2008** Heavy Duty Mini Sander

- High durability of SI-2007A is a model for heavy duty

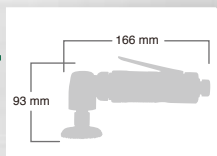

**SI-2107A** Mini Sander

- Angle head dual action sander with 2" Velcro pad
- You can use 2" sanding paper, wool buff or sponge buff
- A good tool for sanding and polishing where space is limited
- High quality gears provide long tool life
- Dual action for easy operation and a good finish

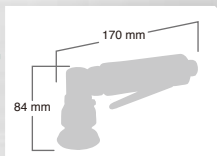

**SI-2108** Heavy Duty Mini Sander

- High durability of SI-2107A is a model for heavy duty

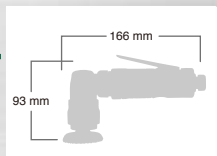

**NEW**

**SI-2110** Mini Dual Action Sander

- Engineered for the most aggressive sanding applications
- Durable ball-bearing construction ensures, a smooth power delivery

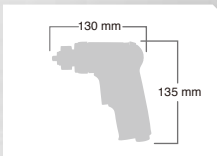

**NEW**

**SI-2202** Disc Sander

- Ideal for the removal of rust, surface deposits, and welds in hard-to-reach areas
- Double-sided, adjustable speed settings provide variability for a broader range of applications
- Designed for direct mounting of the 3M Roloc Pad

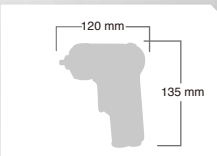

**SI-2201** Disc Sander

- Designed for direct mounting of the 3M Roloc Pad
- No adaptors necessary
- Option : 2" and 3" pads are available

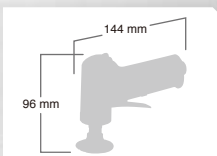

**SI-2210** Disc Sander

- A long seller in the market. Very popular high speed 4" disc sander
- Easy one hand operation
- Disc inside dia.

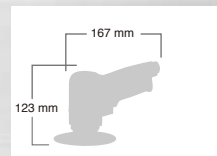

**SI-2300** Disc Sander

- Vertical grip for stable and easy operation sander with 7" disc

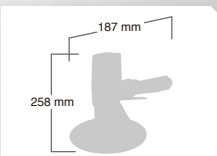

Model Number	Pad/Disc Size mm/(in.)	Spindle Size Female	Orbit Dia mm	Free Speed rpm	Out Put Watt	Weight kg/(lb)	Noise Level dBA/(power)	Vibration m/s <sup>2</sup>	Avg. Air Consumption CFM	Air Inlet Size in.	Hose Size mm/(in.)
SI-3102/3102M	75/(3")	5/16-24UNF	3	12,000	153	0.54/(1.19)	76/(88)	< 2.5	2.5	1/4	10/(3/8)
SI-3112/3112M	75/(3")	5/16-24UNF	3	12,000	153	0.89/(1.96)	76/(88)	< 2.5	2.5	1/4	10/(3/8)
SI-2007A	48/(2")	M6x1	—	13,000	127	0.48/(1.07)	88/(101)	< 2.5	2.3	1/4	10/(3/8)
SI-2008	48/(2")	M6x1	—	13,000	175	0.62/(1.36)	88/(101)	< 2.5	2.8	1/4	10/(3/8)
SI-2107A	48/(2")	M6x1	3	8,500	127	0.55/(1.20)	85/(98)	< 2.5	1.2	1/4	10/(3/8)
SI-2108	48/(2")	M6x1	3	12,500	175	0.62/(1.36)	88/(101)	< 2.5	2.4	1/4	10/(3/8)

Model Number	Pad/Disc Size mm/(in.)	Spindle Size Female	Free Speed rpm	Out Put Watt	Weight kg/(lb)	Noise Level dBA/(power)	Vibration m/s <sup>2</sup>	Avg. Air Consumption CFM	Air Inlet Size in.	Hose Size mm/(in.)
SI-2110	75/(3")	5/16-24UNC	14,000	168	0.52	84/(97)	4.0	2.5	1/4	10
SI-2202	75/(3")	1/4-20UNC	14,000	168	0.46	84/(97)	< 2.5	2.5	1/4	10
SI-2201	75/(3")	1/4-20UNC	17,000	174	0.50/(1.10)	84/(97)	< 2.5	2.5	1/4	10/(3/8)
SI-2210	100/(4")	7/16-20UNF	18,000	475	0.99/(2.17)	96/(109)	< 2.5	3.9	1/4	10/(3/8)
SI-2300	180/(7")	5/8-11UNC	4,000	409	2.27/(5.01)	87/(99)	< 2.5	3.9	1/4	10/(3/8)



**SI-2026**

Disc Sander

- Angle head disc sander for 5" disc. For general sanding and polishing
- High quality air motor provides high power, durability and reduced vibration
- Side handle for smooth and stable sanding

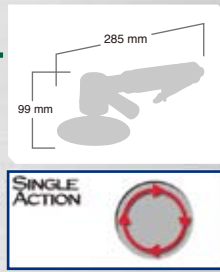

**SI-2351**

Disc Sander

- Angle head sander with 7" disc
- Side handle for smooth and stable sanding
- Rear exhaust through the handle directs air away from operator and workplace

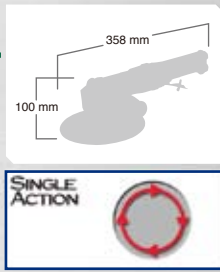

**SI-3200A**

Oscillation Sander

- Self suck system protects operator from harmful powder of paint and filler
- Oscillating mechanism tool with a triangular pad. For delicate and fine sanding work
- Special designed oscillation sander for narrow place and corner

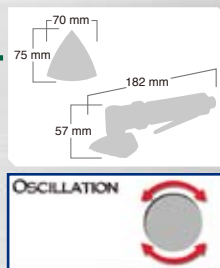

36 188-3A ☆

**SI-3300**

Oscillation Sander

- Oscillating mechanism tool with 30mm diameter polishing pad
- Special design for the polishing of very small scratches, marks or dust on fresh paint of motorcar's body panel
- A specially designed oscillation sander for taking off bubble and scratch on paint surface
- Option : 310GS-5 Hard pad

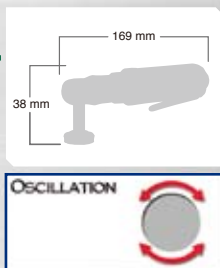

37 310GS-4 ☆

38 310GS-5 ☆

**SI-2322WR**

Wet Sander

- Wet sander designed for stone sanding and polishing with water
- 3", 4" or 5" rubber Velcro pad + diamond abrasive is the best choice for the too
- Supplied with 16mm thread spindle
- Perfect waterproof mechanism ensures a long working life



39 1110A-80 ☆

**SI-2322WR-E**

Wet Sander

- The same quality features of SI-2322 with 14mm thread spindle
- Comfortable combination lever of throttle and air regulator



40 1110A-80E ☆

Model Number	Pad/Disc Size mm/(in.)	Spindle Size Female	Oscillating Angle	Free Speed rpm	Out Put Watt	Weight kg/(lb)	Noise Level dBA/ (power)	Vibration m/s <sup>2</sup>	Avg. Air Consumption CFM	Air Inlet Size in.	Hose Size mm/ (in.)
SI-2026	125/(5")	5/8-11UNC	—	5,000	491	1.50/(3.31)	87/(100)	< 2.5	4.4	1/4	10/ (3/8)
SI-2351	180/(7")	5/8-11UNC	—	4,500	458	0.21/(0.47)	85/(97)	< 2.5	4.1	1/4	10/(3/8)
SI-3200A	△75×70	M8×1.25	2.8°	★19,000	173	0.65/(1.43)	85/(98)	3.5	2.4	1/4	10/ (3/8)
SI-3300	ø30	M6×1	2.3°	★ 600	108	0.57/(1.25)	86/(99)	< 2.5	1.0	1/4	10/ (3/8)
SI-2322WR	ø80	M16	—	5,000	435	1.30/(2.87)	78/(91)	< 2.5	4.0	1/4	10/ (3/8)
SI-2322WR-E	ø80	M14	—	5,000	435	1.30/(2.87)	78/(91)	< 2.5	4.0	1/4	10/ (3/8)

★ : opm (Oscillation Per Minutes)

**ROUND TYPE  
(NO HOLE)**

**M-75H**

3" Velcro Pad  
5/16-24UNF



01

**P-75H**

3" Leather Pad  
5/16-24UNF



02

**ME-125H**

5" Velcro Pad  
5/16-24UNF



03

**PE-125H**

5" Leather Pad  
5/16-24UNF



04

**M-150H**

6" Velcro Pad  
5/16-24UNF



05

**P-150H**

6" Leather Pad  
5/16-24UNF



06

**257-2A**

8" Leather Pad



07

**486-3**

6" Velcro Pad  
5/16-24UNF



08

**ROUND SHAPE  
PAD WITH HOLES**

**M-75HD**

3" Velcro Pad with 3holes  
5/16-24UNF



09

**P-75HD**

3" Leather Pad with 3holes  
5/16-24UNF



10

**ME-125HD**

5" Velcro Pad with 6holes  
5/16-24UNF



11

**PE-125HD**

5" Leather Pad with 6holes  
5/16-24UNF



12

**M-150HD 6**

6" Velcro Pad 3M Type  
5/16-24UNF

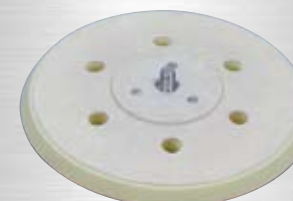

13

**P-150HD 6**

6" Leather Pad 3M Type  
5/16-24UNF



14

IMPACT WRENCHES  
DRIVERS  
RATCHET WRENCHES  
SANDERS  
POLISHER  
GRINDERS  
DRILLS/SPOTMILLS  
CUTTING TOOLS  
OTHERS  
MAINTENANCE CHECK  
ACCESSORIES  
QUALITY



**ROUND SHAPE PAD WITH HOLES**

**M-150HD 9**  
6" Velcro Pad with 9holes  
5/16-24UNF



15

**M-150HD 3-9**  
6" Velcro Pad with 9holes  
5/16-24UNF



16

**P-150HD 3-9**  
6" Leather Pad with 9holes  
5/16-24UNF



17

**P-150HD 9**  
6" Leather Pad with 9holes  
5/16-24UNF



18

**1140-14M**  
5" Velcro Pad



19

**1140-59M**  
6" Velcro Pad



20

**SQUARE TYPE (NO HOLE) & SQUARE TYPE PAD WITH HOLES**

**M-3003**  
Velcro Pad incl. Plate(490-58B) No hole



21

**P-3003**  
Leather Pad incl. Plate(490-58B) No hole



22

**M-3007**  
Velcro Pad incl. Plate(477-44)



23

**P-3007**  
Leather Pad incl. Plate(477-44)



24

**M-3013D**  
Velcro Pad incl. Plate(490-58B) with hole



25

**P-3013D**  
Leather Pad incl. Plate(490-58B) with hole



26

**475-22**  
Leather Pad



27

**477A-5EM**  
Velcro Pad incl



28

**477A-5EL**  
Leather Pad incl



29

**MINI PAD & BUFF & DISC**

**MESP-65**  
φ65mm Sanding Disc



30

**262-21MD**  
φ48mm Velcro Pad  
M6



31

**SHP-50M**  
Sanding Paper



32

**114DA-12**  
φ70mm Velcro Pad  
M6



33

**M-20x60/B**  
φ60mm Sponge Buff



34

**M-60**  
φ60mm Wool Buff



35

**TRIANGLE TYPE & DUST CHIP ELIMINATOR PAD**

**118-3A**  
Triangle Sanding Pad



36

**310GS-4**  
φ30mm SoftPad  
M6



37

**310GS-5**  
φ30mm HardPad  
M6



38

**WET SANDER PAD**

**1110A-80**  
φ80mm Velcro Pad (M16 P=2)



39

**1110A-80E**  
φ80mm Velcro Pad (M14 P=2)



40

**Regulator**

**181-45**  
Regulator



41

IMPACT WRENCHES  
DRIVERS  
RATCHET WRENCHES  
SANDERS  
POLISHER  
GRINDERS  
DRILLS/POTMILLS  
CUTTING TOOLS  
OTHERS  
MAINTENANCE CHECK  
QUALITY  
ACCESSORIES



# POLISHERS

## POLISHERS / DUAL ACTION POLISHERS • SINGLE ACTION POLISHERS • GEARED DUAL ACTION POLISHERS

★ : Attachment Included  
☆ : Accessories

**NEW**  
**SI-2415** Geared Dual Action Polisher

- Geared polisher with 6" Velcro pad. 1,200rpm low speed and high torque
- Designed for the wax polishing of painted motorcar body panels
- Either a wool buff or sponge buff can be used
- Geared dual action for easy operation





09 1145-101 ★ 10 1145-102 ★

**SI-3100P** Dual Action Polisher

- Dual action polisher with 6" Velcro pad
- Designed for the wax polishing of painted motorcar body panel
- Either a wool buff or sponge buff can be used
- Uniform wax work with dual action
- Professional finish without special skill





04 M-40x165/B ★ 05 M-150 ★

**SI-2221** Single Action Polisher

- Geared polisher with 3" Velcro pad
- Light and compact body
- Either a wool buff or sponge buff can be used
- Designed for Polishing and Buffing painted surface in confined areas
- The tool most suitable for repairing small scratch or dust on painted surfaces





02 114DA-12 ☆ 07 119-101 ★  
08 119-102 ★ 09 NVP75-240 ★

**SI-2400** Single Action Polisher

- Vertical polisher with 7" back up disc
- Vertical grip for stable and easy operation





**SI-2405** Single Action Polisher

- Vertical polisher with 6" pad
- Light weight
- Precise and high quality 2 gear mechanism ensures high power transfer
- Can also be used as a sander





01 M-150H ★

**SI-2451** Single Action Polisher

- Angle head polisher with 7" back up disc
- Rear exhaust through the handle directs air away from operator and workplace





Model Number	Buff Pad Size mm/(in.)	Spindle Size Male	Spindle Size Female	Orbit Dia mm	Free Speed rpm	OutPut Watt	Weight kg/(lb)	Noise Level dBA/(power)	Vibration m/s <sup>2</sup>	Avg. Air Consumption CFM
SI-2415	140/(6")	—	—	4.4	1,200	—	1.45	90/(103)	< 2.5	3.4
SI-3100P	150/(6")	—	5/16-24UNF	6	8,000	542	1.81/(3.99)	80/(93)	5.3	2.3
SI-2221	70/(3")	—	M6x1	—	4,500	203	0.64/(1.42)	87/(99)	< 2.5	2.5
SI-2400	180/(7")	5/8-11UNC	—	—	2,000	511	2.24/(4.94)	89/(102)	< 2.5	4.0
SI-2405	150/(6")	—	5/16-24UNF	—	1,800	241	1.17/(2.58)	83/(96)	< 2.5	2.8
SI-2451	180/(7")	5/8-11UNC	—	—	2,300	482	2.13/(4.69)	86/(99)	< 2.5	3.9

IMPACT WRENCHES  
DRIVERS  
RATCHET WRENCHES  
SANDERS  
POLISHER  
GRINDERS  
DRILLS/SPOTMILLS  
CUTTING TOOLS  
OTHERS  
MAINTENANCE CHECK  
QUALITY  
ACCESSORIES



# POLISHERS / SINGLE ACTION POLISHERS

★ : Attachment Included  
☆ : Accessories

## SI-2009 Single Action Polisher

- Compact body design for reduce weight
- Low Speed Single Action Sander
- New design for 3" pad size

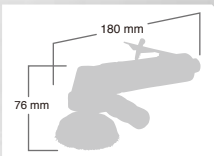

06 M-75H ★ 07 119-101 ★



08 119-102 ★

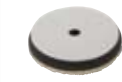

## SI-2009H Single Action Polisher

- Compact body design for reduce weight
- High Speed Single Action Sander
- New design for 3" buff pad size

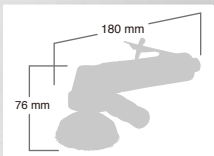

06 M-75H ★ 07 119-101 ★



08 119-102 ★

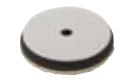

Model Number	Buff Pad Size mm/(in.)	Spindle Size Female	Free Speed rpm	OutPut Watt	Weight kg/(lb)	Noise Level dBA/(power)	Vibration m/s <sup>2</sup>	Avg. Air Consumption CFM
SI-2009	80/(3")	5/16-24UNF	2,600	180	0.68/(1.49)	80/(93)	< 2.5	2.5
SI-2009H	80/(3")	5/16-24UNF	5,000	190	0.68/(1.50)	80/(93)	< 2.5	2.1

# POLISHER ACCESSORIES

## M-150H

6" Velcro Pad  
5/16-24UNF



ROUND TYPE (NO HOLE) 01

## 114DA-12

ø3" Velcro Pad Thread  
M6



ROUND TYPE MINI PAD (NO HOLE) 02

## M-40x165/B

Sponge Buff



BUFF 03

## M-150

Wool Buff



BUFF 04

## M-75H

3" Velcro Pad  
5/16-24UNF



05

## 119-101

ø80mm Sponge Buff

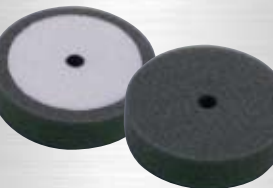

MINI BUFF 06

## 119-102

ø80mm Wool Buff



MINI BUFF 07

## NVP75-240

ø75mm Sanding Paper #120



MINI BUFF 08

## 1145-101

ø165mm Wool Buff



BUFF 09

## 1145-102

ø165mm Sponge Buff

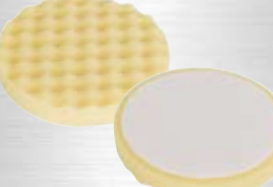

BUFF 10

# GRINDERS



**SI-2001S**

Die Grinder

**SI-2001S-6 : 6mm Collet model**

- Small body size die grinder
- 1/4" collet

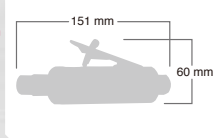

- O1 330-24** 1/4" Collet  
★ SI-2001S / ☆ SI-2001S-6
- O2 330-19** 6mm Collet  
★ SI-2001S / ☆ SI-2001S-6
- O3 330-25** 1/8" Collet  
★ SI-2001S / ☆ SI-2001S-6
- O4 330-26** 3mm Collet  
★ SI-2001S / ☆ SI-2001S-6

**SI-2002**

Die Grinder

**SI-2002-6 : 6mm Collet model**

- Compact, lightweight, ergonomic design
- Feather touch throttle lever for easy operation
- A plastic body cover absorbs tool vibrations and protects your hand from the cold
- 1/4" collet
- Built-in air regulator for easy adjustment

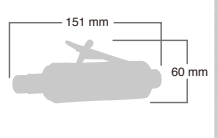

- O1 330-24** 1/4" Collet  
★ SI-2002 / ☆ SI-2002-6
- O2 330-19** 6mm Collet  
★ SI-2002 / ☆ SI-2002-6
- O3 330-25** 1/8" Collet  
★ SI-2002 / ☆ SI-2002-6
- O4 330-26** 3mm Collet  
★ SI-2002 / ☆ SI-2002-6

**SI-2006S**

Die Grinder

**SI-2006S-6 : 6mm Collet model**

- Small body size, angle head die grinder
- 1/4" collet
- Compact, lightweight, ergonomic design and feather touch throttle lever for easy operation
- Lever throttle with safety lock

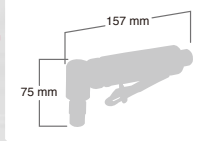

- O1 330-24** 1/4" Collet  
★ SI-2006S / ☆ SI-2006S-6
- O2 330-19** 6mm Collet  
★ SI-2006S / ☆ SI-2006S-6
- O3 330-25** 1/8" Collet  
★ SI-2006S / ☆ SI-2006S-6
- O4 330-26** 3mm Collet  
★ SI-2006S / ☆ SI-2006S-6

**SI-2005**

Die Grinder

**SI-2005-6 : 6mm Collet model**

- Small body size, angle head die grinder with a plastic grip cover
- 1/4" collet
- Compact, lightweight, ergonomic design and feather touch throttle lever for easy operation
- A plastic body cover absorbs tool vibrations and protects your hand from the cold
- Lever throttle with safety lock

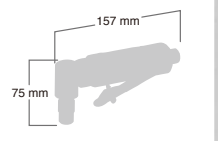

- O1 330-24** 1/4" Collet  
★ SI-2005 / ☆ SI-2005-6
- O2 330-19** 6mm Collet  
★ SI-2005 / ☆ SI-2005-6
- O3 330-25** 1/8" Collet  
★ SI-2005 / ☆ SI-2005-6
- O4 330-26** 3mm Collet  
★ SI-2005 / ☆ SI-2005-6

**SI-2011S**

Die Grinder

**SI-2011S-6 : 6mm Collet model**

- Medium body size die grinder
- 1/4" collet
- Rear exhaust directs air away from operator and work place
- Lever throttle with safety lock
- Compact, lightweight, ergonomic design and feather touch throttle lever for easy operation

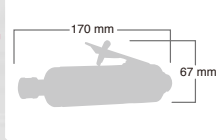

- O1 330-24** 1/4" Collet  
★ SI-2011S / ☆ SI-2011S-6
- O2 330-19** 6mm Collet  
★ SI-2011S / ☆ SI-2011S-6
- O3 330-25** 1/8" Collet  
★ SI-2011S / ☆ SI-2011S-6
- O4 330-26** 3mm Collet  
★ SI-2011S / ☆ SI-2011S-6

**SI-2012**

Die Grinder

**SI-2012-6 : 6mm Collet model**

- Medium body size die grinder with a plastic grip cover
- 1/4" collet
- Compact, lightweight, ergonomic design and feather touch throttle lever for easy operation
- A plastic body cover absorbs tool vibrations and protects your hand from the cold

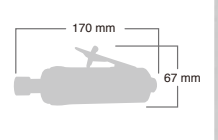

- O1 330-24** 1/4" Collet  
★ SI-2012 / ☆ SI-2012-6
- O2 330-19** 6mm Collet  
★ SI-2012 / ☆ SI-2012-6
- O3 330-25** 1/8" Collet  
★ SI-2012 / ☆ SI-2012-6
- O4 330-26** 3mm Collet  
★ SI-2012 / ☆ SI-2012-6

**SI-2015A**

Die Grinder

**SI-2015A-6 : 6mm Collet model**

- Planetary geared die grinder. 5,500rpm low speed and high torque
- 1/4" and 6mm collets are available
- Compact, lightweight, ergonomic design and feather touch throttle lever for easy operation
- A plastic body cover absorbs tool vibrations and protects your hand from the cold

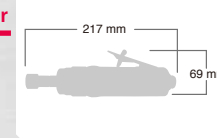

- O1 330-24** 1/4" Collet  
★ SI-2015A / ☆ SI-2015A-6
- O2 330-19** 6mm Collet  
★ SI-2015A / ☆ SI-2015A-6
- O3 330-25** 1/8" Collet  
★ SI-2015A / ☆ SI-2015A-6
- O4 330-26** 3mm Collet  
★ SI-2015A / ☆ SI-2015A-6
- O5 210-5-1A** Dead handle set  
★ SI-2015A / ☆ SI-2015A-6

**SI-2010**

Die Grinder

**SI-2010-6 : 6mm Collet model**

- Compact, lightweight, ergonomic design and feather touch throttle lever for easy operation
- A plastic body cover absorbs tool vibrations and protects your hand from the cold

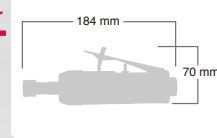

- O1 330-24** 1/4" Collet  
★ SI-2010 / ☆ SI-2010-6
- O2 330-19** 6mm Collet  
★ SI-2010 / ☆ SI-2010-6
- O3 330-25** 1/8" Collet  
★ SI-2010 / ☆ SI-2010-6
- O4 330-26** 3mm Collet  
★ SI-2010 / ☆ SI-2010-6

**SI-2022S**

Die Grinder

**SI-2022S-6 : 6mm Collet model**

- Die grinder with the extended shaft
- 1/4" collet
- Special designed extended die grinder for unreachable place

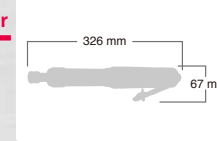

- O1 330-24** 1/4" Collet  
★ SI-2022S / ☆ SI-2022S-6
- O2 330-19** 6mm Collet  
★ SI-2022S / ☆ SI-2022S-6
- O3 330-25** 1/8" Collet  
★ SI-2022S / ☆ SI-2022S-6
- O4 330-26** 3mm Collet  
★ SI-2022S / ☆ SI-2022S-6

**SI-2023**

Die Grinder

**SI-2023-6 : 6mm Collet model**

- Low Speed Die Grinder
- 1/4" collet
- Sander with the extended shaft
- Special designed extended Sander for unreachable place

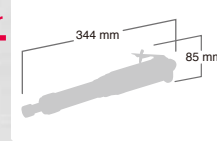

- O1 330-24** 1/4" Collet  
★ SI-2023 / ☆ SI-2023-6
- O2 330-19** 6mm Collet  
★ SI-2023 / ☆ SI-2023-6
- O3 330-25** 1/8" Collet  
★ SI-2023 / ☆ SI-2023-6
- O4 330-26** 3mm Collet  
★ SI-2023 / ☆ SI-2023-6

**SI-2033**

Cut off Grinder

- A straight grinder designed for 3" cut off discs
- For cutting sheet metal or pipe
- Especially useful for cutting the exhaust pipe on motorcars
- Compact and lightweight body with lever throttle for safety operation

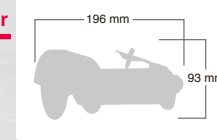

- O6 175-29** ★  
3" Cut Disc

**SI-2501L/2501**

Disc Grinder

- Light weight 4" disc grinder with rotary throttle
- 40% lighter than SI-2500
- Speed governor assures safety operation
- Compact and lightweight body with rotary throttle for easy operation
- Precise gear mechanism assures the highest power transfer, durability and reduced vibration

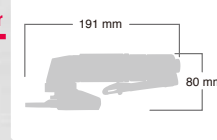

- SI-2501**
- O7 240-6** 4" Disc 15mm Hole  
★ SI-2501L / ☆ SI-2501
- O8 240-71** 4" Disc 16mm Hole  
★ SI-2501L / ☆ SI-2501
- O9 240C-1** Disc Nut for 16mm Hole  
★ SI-2501L / ☆ SI-2501
- O10 380-44** Disc Nut for 15mm Hole  
★ SI-2501L / ☆ SI-2501

Model Number	Collet Size	Free Speed rpm (MAX)	Output Watt	Weight kg/(lb)	Noise Level dBA/(power)	Vibration m/s <sup>2</sup>	Avg. Air Consumption CFM
SI-2001S/2001S-6	ø1/4" / ø6	25,000	173	0.37/(0.82)	85/(98)	< 2.5	2.7
SI-2002/2002-6	ø1/4" / ø6	27,000	219	0.37/(0.83)	86/(98)	< 2.5	2.6
SI-2006S/2006S-6	ø1/4" / ø6	25,000	127	0.49/(1.08)	89/(101)	3.9	2.3
SI-2005/2005-6	ø1/4" / ø6	25,000	171	0.50/(1.10)	89/(101)	< 2.5	2.4
SI-2011S/2011S-6	ø1/4" / ø6	25,000	422	0.60/(1.32)	93/(105)	< 2.5	4.0
SI-2012/2012-6	ø1/4" / ø6	25,000	388	0.60/(1.31)	92/(105)	< 2.5	4.0

Model Number	Disc Size mm/(in.)	Collet Size	Spindle Size	Free Speed rpm (MAX)	Output Watt	Weight kg/(lb)	Noise Level dBA/(power)	Vibration m/s <sup>2</sup>	Avg. Air Consumption CFM
SI-2015A/2015A-6	—	ø1/4" / ø6	—	7,500	457	0.91/(2.01)	95/(108)	< 2.5	4.2
SI-2010/2010-6	—	ø1/4" / ø6	—	25,000	247	0.52/(1.14)	88/(101)	< 2.5	1.8
SI-2022S/2022S-6	—	ø1/4" / ø6	—	24,000	537	1.34/(2.94)	88/(101)	< 2.5	4.5
SI-2023/2023-6	—	ø1/4" / ø6	—	6,000	435	1.70/(3.75)	95/(107)	< 2.5	3.8
SI-2033	75/(3")	—	ø9.5/(3/8")	20,500	347	1.00/(2.21)	93/(106)	< 2.5	4.0
SI-2501L/2501	100/(4")	—	M10×1.5	13,000	303	1.04 / 0.91 (2.29) / (2.01)	83 / 84 (96) / (96)	5.7	2.7/2.2



**SI-2500L/2500**

Disc Grinder

- The high quality air motor used ensures the highest power and durability, while reducing vibration
- A trouble free tool for industry use

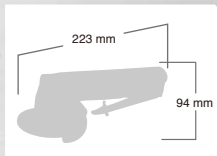

**SI-2515LA**

Disc Grinder

- 5" Disc grinder with safety lever throttle and 14mm thread spindle
- Speed governor assures safety operation
- Spindle lock button enable exchanging disc quickly
- Rear exhaust and lever throttle with safety lock
- Disc one push lock button model

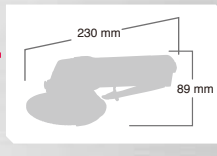

**SI-2505L**

Disc Grinder

- 5" Disc grinder with safety lever throttle
- For this model because of the safety reason
- Speed governor assures safety operation
- Lever throttle with safety lock

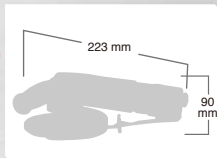

**SI-2600L**

Disc Grinder

- 7" Disc grinder with safety lever throttle
- Speed governor assures safety operation
- High quality air motor assures high power, durability, reducing vibration and trouble free use

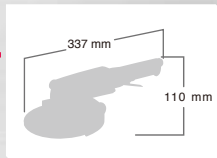

**SI-2050AG**

Micro Grinder

- High speed angle head disc grinder with 30mm diameter disc
- 20,000rpm
- For exact and delicate work

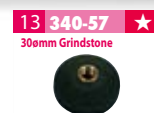
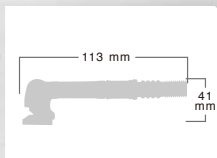

**SI-2051SG**

Micro Grinder

- High speed die grinder with 3mm or 1/8" collet
- Low vibration and noise allows extended use
- Option : 1/8" Dia collet

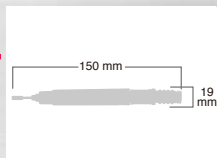

Model Number	Disc Size mm/(in.)	Spindle Size	Free Speed rpm (MAX)	Output Watt	Weight kg/(lb)	Noise Level dBA/ (power)	Vibration m/s <sup>2</sup>	Avg. Air Consumption CFM
SI-2500L/2500	100/(4")	M10×1.5	12,700	443	1.82 / 1.87 (4.02) / (4.11)	83 (96) / 82 (94)	2.9	2.7/2.4
SI-2515LA	125/(5")	M14×2	12,000	651	1.65/(3.65)	84/(96)	2.9	2.8
SI-2505L	125/(5")	ø22/(7/8")	12,000	443	1.91/(4.22)	86/(98)	2.8	3.3
SI-2600L	180/(7")	M10×1.5	7,500	754	3.24/(7.15)	98/(110)	< 2.5	4.0
SI-2050AG	ø30	M7×0.75	20,000	—	0.23/(0.52)	83/(96)	< 2.5	1.1
Model Number	Collet Size	Free Speed rpm (MAX)	Weight kg/(lb)	Noise Level dBA/ (power)	Vibration m/s <sup>2</sup>	Avg. Air Consumption CFM		
SI-2051SG	ø3 , 1/8"	50,000	0.19/(0.43)	78/(91)	< 2.5	1.0		

# DRILLS / SPOT MILLS



SI-2015AD

Drill

- 3/8" capacity geared straight grip drill
- Specially designed tool for use in narrow place

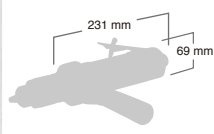

- 01 KD-004 (3/8" Drill Chuck w/Handle KK) ★
- 02 LX10 ☆
- 12 210-5-1A ☆

SI-5100A

Drill

- 3/8" capacity geared pistol grip drill
- High speed drill for soft metal

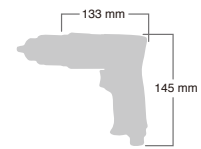

- 01 KD-004 (3/8" Drill Chuck w/Handle KK) ★
- 02 LX10 ☆

SI-5200A

Drill

- 1/2" capacity, geared, pistol grip drill
- 500rpm low speed and high torque
- Ergonomic, compact, lightweight design with feather touch trigger for easy drill bit centering
- Precise planetary gear mechanism with needle roller assures high power, durability and reducing vibration
- Side handle for greater hand grip and control for easy operation

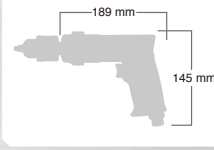

- 04 KD-003A (1/2" Drill Chuck w/Handle KK) ★
- 03 LM13W ☆
- 12 210-5-1A ☆

SI-5300A

Drill

- 3/8" capacity geared pistol grip drill
- Heavy duty and the best selling model of the drills
- Precise planetary gear mechanism with needle roller assures high power, durability and reducing vibration
- Ergonomic, compact, lightweight design with feather touch trigger for easy centering

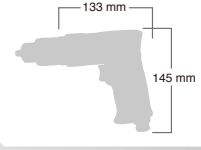

- 01 KD-004 (3/8" Drill Chuck w/Handle KK) ★
- 02 LX10 ☆

SI-5305A

Drill

- 3/8" capacity geared pistol grip reversible drill
- Handy reverse mechanism
- Can be used for tapping work by utilizing the reverse function

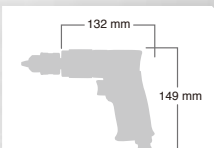

- 01 KD-004 (3/8" Drill Chuck w/Handle KK) ★
- 02 LX10 ☆
- 08 100 ☆
- 12 210-5-1A ☆

SI-5305-8A

Drill

- 1/2" capacity geared pistol grip reversible drill. 800rpm low speed and high torque. Handy reverse mechanism
- Can be used for tapping work by utilizing the reverse function
- Side handle for greater hand grip and control for easy operation

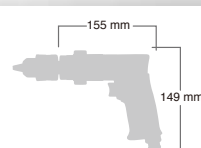

- 04 KD-003A (1/2" Drill Chuck w/Handle KK) ★
- 03 LM13W ☆
- 12 210-5-1A ☆

SI-5501

Drill

- 3/8" capacity geared pistol grip drill
- Super light weight & compact design with solid composite body
- Based on two-layer molded rubber grip giving comfortable grip and reducing vibration
- A swivel lever for regulator can be used with one hand allowing easy operation

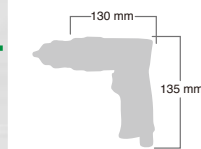

- 05 KD-002 (3/8" Drill Chuck w/Handle KG1) ★
- 02 LX10 ☆

SI-5506

Drill

- 3/8" capacity geared pistol grip type reverse drill
- Super light weight & compact design with solid composite body
- Based on two-layer molded rubber grip giving comfortable grip and reducing vibration
- A swivel lever for forward & reverse can be used with one hand allowing easy operation

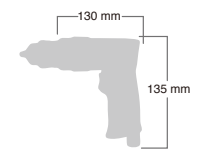

- 05 KD-002 (3/8" Drill Chuck w/Handle KG1) ★
- 02 LX10 ☆

SI-5500

Drill

- 3/8" capacity geared pistol grip drill
- Light duty and reasonable price model
- Ergonomic, compact and lightweight design for easy operation

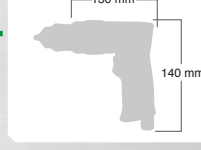

- 05 KD-002 (3/8" Drill Chuck w/Handle KG1) ★
- 02 LX10 ☆

SI-5505

Drill

- 3/8" capacity geared pistol grip drill with solid composite body
- Supplied with keyless chuck
- Solid composite body absorbs the vibration remarkably and also protects your hand in a cold environment
- Keyless chuck enable the quick change of drill bits

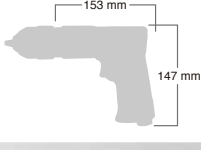

- 02 LX10 ☆
- 01 KD-004 (3/8" Drill Chuck w/Handle KK) ☆

SI-5355

Drill

- 3/8" capacity geared angle head drill
- Designed to facilitate drilling in confined places

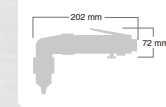

- 01 KD-004 (3/8" Drill Chuck w/Handle KK) ★
- 02 LX10 ☆

SI-5800

Spot Mill

- Specially designed to remove spot welds on body panels of motorcars. Work guide makes easy operation
- Easy to adjust depth of cut
- Special designed tool for spot welding separation
- With ø8mm Mill
- With sleeve for ø65mm Mill

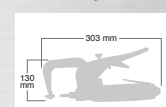

- 09 271-17 ☆
- 10 271-70 ☆
- 11 271-71 ☆

SI-5850A

Spot Mill

- Specially designed to remove spot welds on body panel of motorcars
- Work guide makes easy operation
- Easy to adjust depth of cut
- Special designed tool for spot welding separation
- With ø8mm Mill

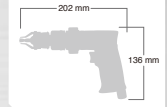

- 09 271-17 ☆
- 12 210-5-1A ☆

Model Number	Free Speed rpm	Chuck Size mm/(in.)	Spindle Size	Drilling Cap mm/(in.)	Out Put Watt	Weight kg/(lb)	Noise Level dBA/(power)	Vibration m/s <sup>2</sup>	Avg. Air Consumption CFM	Hose Size mm/(in.)
SI-2015AD	6,000	10/(3/8)	3/8-24UNF	6/(1/4)	457	1.06/(2.34)	94/(106)	< 2.5	4.2	10/(3/8)
SI-5100A	5,000	10/(3/8)	3/8-24UNF	6/(1/4)	390	0.90/(1.99)	90/(102)	< 2.5	3.3	10/(3/8)
SI-5200A	600	13/(1/2)	3/8-24UNF	13/(1/2)	390	1.42/(3.12)	88/(101)	< 2.5	3.5	10/(3/8)
SI-5300A	2,000	10/(3/8)	3/8-24UNF	10/(3/8)	378	0.91/(2.01)	90/(102)	< 2.5	3.6	10/(3/8)
SI-5305A	2,000	10/(3/8)	3/8-24UNF	10/(3/8)	326	1.02/(2.24)	94/(106)	< 2.5	3.9	10/(3/8)
SI-5305-8A	800	13/(1/2)	3/8-24UNF	13/(1/2)	326	1.45/(3.20)	94/(107)	< 2.5	4.2	10/(3/8)

Model Number	Free Speed rpm	Chuck Size mm/(in.)	Spindle Size	Drilling Cap mm/(in.)	Out Put Watt	Weight kg/(lb)	Noise Level dBA/(power)	Vibration m/s <sup>2</sup>	Avg. Air Consumption CFM	Hose Size mm/(in.)
SI-5501	2,400	10/(3/8)	3/8-24UNF	10/(3/8)	234	0.60/(1.32)	82/(95)	< 2.5	2.2	10/(3/8)
SI-5506	1,700	10/(3/8)	3/8-24UNF	10/(3/8)	146	0.60/(1.32)	81/(94)	< 2.5	2.4	10/(3/8)
SI-5500	2,600	10/(3/8)	3/8-24UNF	10/(3/8)	258	0.79/(1.75)	90/(103)	< 2.5	2.5	10/(3/8)
SI-5505	1,900	10/(3/8)	—	10/(3/8)	158	0.75/(1.65)	86/(99)	< 2.5	2.6	10/(3/8)
SI-5355	1,200	10/(3/8)	3/8-24UNF	10/(3/8)	180	0.94/(2.07)	88/(101)	< 2.5	3.0	10/(3/8)
Model Number	Free Speed rpm	Chuck Size mm/(in.)	Spindle Size	Milling Cap mm/(in.)	Out Put Watt	Weight kg/(lb)	Noise Level dBA/(power)	Vibration m/s <sup>2</sup>	Avg. Air Consumption CFM	Hose Size mm/(in.)
SI-5800	1,600	8/(5/8)	ø8	8/(5/16)	197	1.80/(3.96)	85/(98)	< 2.5	3.0	10/(3/8)
SI-5850A	2,000	8/(5/8)	ø8	8/(5/16)	390	1.39/(3.06)	85/(98)	< 2.5	1.3	10/(3/8)



**KD-004** Chuck / Handle



3/8" Drill Chuck w / Handle KK **01**

**LX10** (Yukiwa) Chuck



3/8" Cap. Keyless Chuck (3/8" Thd.) Optional **02**

**LM13W** (Yukiwa) Chuck



1/2" Cap. Keyless Chuck (3/8" Thd.) Optional **03**

**KD-003A** Chuck / Handle



1/2" Drill Chuck w / Handle KK **04**

**KD-002** Chuck / Handle



3/8" Drill Chuck w / Handle KG1 **05**

**KK** Handle



Chuck Handle for KD-004, SM8K61 & KD-003A **06**

**KG1** Handle



Chuck Handle for KD-002 & SM4G61 **07**

**100** Sleeve Chuck



Collet Driver **08**

**271-17** Milling Cutter



φ8mm Milling Cutter **09**

**271-70** Milling Cutter



φ6.5mm Milling Cutter **10**

**271-71** Milling Cutter



Sleeve 6.5mm Milling Cutter **11**

**210-5-1A** Dead Handle set



**12**

# CUTTING TOOLS



**SI-4700B**

Saw

- This air saw is the most popular tool for cutting body panel of motorcars and is one of longest selling models in the automotive repair market
- A popular tool at reasonable price

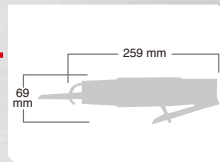

**SI-4700B**

**Standard Accessories**

506-49A Saw blade 32T

**Option Accessories**

1025-49 Saw blade 32T

1025-50 Saw blade 24T

**SI-4710**

Saw

**SI-4710F : Saw blade and 3files set**

- Air saw & file
- An improved model over the SI-4700B
- You can use saw blades, as well as 3 different files with this tool
- Low vibration and high power

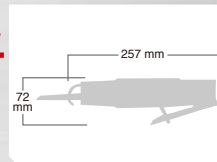

**SI-4710**

**Standard Accessories**

506-49A Saw blade 32T

**Option Accessories**

1025-49 Saw blade 32T

1025-50 Saw blade 24T

506P-56F Flat file

506P-56R Round file

506P-56T Triangle file

**SI-4710F : Saw Blade and 3files set**

**Standard Accessories**

506-49A Saw blade 32T

506P-56F Flat file

506P-56R Round file

506P-56T Triangle file

**Option Accessories**

1025-49 Saw blade 32T

1025-50 Saw blade 24T

**SI-4730**

Saw

- Air saw & file with rotary motor
- SI-4700B & SI-4710 are worked by piston but this model has a rotary air motor and makes working strokes through the gears
- Smooth operation, low vibration and low noise
- Amazing non-stop cutting with extremely low use fatigue

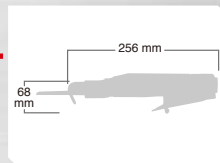

**SI-4730**

**Standard Accessories**

1025-49 Saw blade 32T

506P-56F Flat file

506P-56R Round file

506P-56T Triangle file

**Option Accessories**

1025-50 Saw blade 24T

**NEW**

**SI-4300**

Oscillation Cutter

- Oscillation cutting tool specially designed to cut the body panels of motorcars
- Two different cutting blades are supplied with the tool
- Specially designed tool for car repair shop
- The depth of the cut can be adjusted

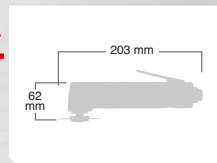

**12 508-45A** ★

**13 508-45B** ★

**18 508-44** ★

**SI-4600**

Nibbler

- Air nibbler for cutting sheet metal
- The use of a punch and die makes cutting metal quick
- Can be used to cut in a curved line

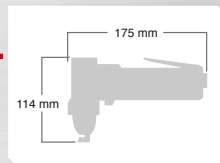

**10 502-42** ★

**11 502-41** ★

**SI-4500**

Shear

- Air shear
- 3 blades shear head makes smooth cutting work for sheet metal
- For speedy cutting of sheet metal

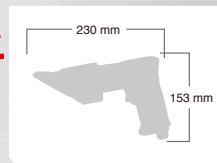

**07/08/09 160-2,3,4** ★

Blade Set

160-2 160-3 160-4

Model Number	File Shank Opening mm/(in.)	Cutting cap mm/(in.)	Free Speed rpm	Out Put W	Weight kg/(lb)	Noise Level dBA/ (power)	Vibration m/s <sup>2</sup>	Avg. Air Consumption CFM	Air Inlet Size in.	Hose Size mm/ (in.)
SI-4700B	—	3/(1/8)	10,000	—	0.58/(1.27)	76/(89)	8.0	1.2	1/4	10/ (3/8)
SI-4710/4710F	5/(3/16)	3/(1/8)	10,000	—	0.80/(1.76)	87/(100)	7.9	1.0	1/4	10/ (3/8)
SI-4730	5/(3/16)	5/(3/16)	6,000	296	0.92/(2.03)	89/(101)	8.0	3.0	1/4	10/ (3/8)
Model Number	Disc Size mm	Oscillating Angle	Free Speed rpm	Out Put W	Weight kg/(lb)	Noise Level dBA/ (power)	Vibration m/s <sup>2</sup>	Avg. Air Consumption CFM	Air Inlet Size in.	Hose Size mm/ (in.)
SI-4300	ø63	2.8°	20,000	—	0.89	90/(103)	4.0	3.2	1/4	10/ (3/8)
Model Number	Cutting Width mm/(in.)	Cutting cap mm/(in.)	Free Speed rpm	Out Put W	Weight kg/(lb)	Noise Level dBA/ (power)	Vibration m/s <sup>2</sup>	Avg. Air Consumption CFM	Air Inlet Size in.	Hose Size mm/ (in.)
SI-4600	4.5/(3/16)	1.6/(1/16)	2,600	316	1.00/(2.20)	94/(106)	< 2.5	3.3	1/4	10/ (3/8)
SI-4500	5.4/(7/32)	1.6/(1/16)	2,600	378	1.26/(2.79)	91/(104)	4.0	3.5	1/4	10/ (3/8)

**SI-2018A**

Trimmer

**SI-2018A-6 : 6mm Collet model**

- Straight die grinder with work guide for trimming laminate
- Easy trimming work for woodwork products
- Designed for use in woodworking where a light weight, compact design is useful
- With 1/4" collet

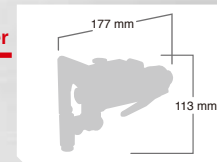

**14 330-24**

★ SI-2018A / ☆ SI-2018A-6

**15 330-19**

★ SI-2018A / ☆ SI-2018A-6

**16 330-25**

★ SI-2018A / ☆ SI-2018A-6

**17 330-26**

★ SI-2018A / ☆ SI-2018A-6

Model Number	Collet Size	Free Speed rpm	Output Watt	Weight kg/ (lb)	Noise Level dBA/ (power)	Vibration m/s <sup>2</sup>	Avg. Air Consumption CFM
SI-2018A/2018A-6	ø1/4" / ø6	22,000	381	0.91/(2.01)	96/(109)	< 2.5	4.2

**CUTTING TOOL ACCESSORIES**

<b>506-49A</b> Saw blade 32T 01	<b>1025-49</b> Saw blade 32T 02	<b>1025-50</b> Saw blade 24T 03	<b>506P-56F</b> Flat File 04	<b>506P-56R</b> Round File 05
<b>506P-56T</b> Triangle File 06	<b>160-2</b> Center Blade 07	<b>160-3</b> Right Blade 08	<b>160-4</b> Left Blade 09	<b>502-42</b> Punch 10
<b>502-41</b> Die 11	<b>508-45A</b> Cutting Wheel 12	<b>508-45B</b> Cutting Blade 13	<b>330-24</b> 1/4" Collet 14	<b>330-19</b> 6mm Collet 15
<b>330-25</b> 1/8" Collet 16	<b>330-26</b> 3mm Collet 17	<b>508-44</b> Adjuster 18	<b>508-45A &amp; 508-44</b> 6mm CUT 4mm CUT 2mm CUT	



# OTHERS

## OTHERS / AIR HAMMER

★ : Attachment Included  
☆ : Accessories

### SI-4120A

Air Hammer

- Pistol grip air hammer for 10.2mm diameter chisels (.401" shank)
- Many kinds of the chisels are available as accessories
- High speed piston power of 2,600 times per min
- Powerful piston enable the tool to cope with many kinds of work

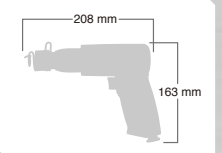

01 400-8 ★



Model Number	Shank Size in./ (mm)	Stroke length mm	Free Blow Speed spm	Weight kg/ (lb)	Noise Level dBA/ (power)	Vibration m/s <sup>2</sup>	Avg. Air Consumption CFM	Air Inlet Size in.	Hose Size mm/ (in.)	Type of Shank
SI-4120A	.401/ (10.2)	Max 10	2,600	1.60/ (3.52)	104/ (116)	9.0	3.0	1/4	10/ (3/8)	Round

### AIR HAMMER ACCESSORIES

Special Accessories .401 Shank CHISELS

All products are Made in Japan.

No.801		TIE ROD TOOL	No.813		RIVET CUTTER
No.802		TAIL PIPE CUTTER	No.814		BLANK CHISEL
No.803		FORK 21/23" OPENING	No.815		SPOT WELD BREAKER
No.803J		FORK 15/16" OPENING	No.816		SHEET METAL B
No.804		BUSHING REMOVER	No.817		BUSHING DRIVER
No.805		SCRAPER	No.818		FLAT BEND
No.806		BUSHING SPLITTER	No.819		SHEET METAL PUNCH
No.807		SHEET METAL A	No.820		PANEL CLIPPER
No.808		MUFFER CUTTER	No.821		SMOOTHING HAMMER
No.809		DOUBLE EDGE PANEL CUTTER	No.822		STRAIGHT PUNCH
No.810		FLAT 7" LONG	No.823		PAINT SCRAPER
No.811		FLAT 9" LONG	No.824		SHOCK ABSORBER CHISEL
No.812		TAPER PUNCH	No.825		MOIL POINT



# OTHERS / NEEDLE SCALER • HYDRO PUNCHER

## SI-4150 Needle Scaler

- Straight grip needle scaler for removing rust or old paint. It provides very good working on uneven or rough surface
- Resign grip for a soft feeling to the hand and improved comfort in winter or cold climate regions
- Mechanism actuated by air power only, not using springs reduces reaction time and improves the smooth actuation
- Simple mechanism provides easy maintenance and needle replacement

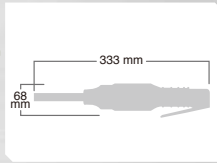

02 820-11 ★

## SI-4800 Hydro Puncher

- Punching and flanging tool is useful for panel beating work
- Best tool for welding work of car body

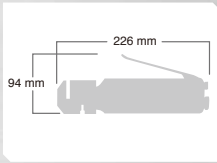

Model Number	Stroke length mm	Free Blow Speed spm	Weight kg/ (lb)	Noise Level dBA/ (power)	Vibration m/s <sup>2</sup>	Avg. Air Consumption CFM	Air Inlet Size in.	Hose Size mm/ (in.)
SI-4150	Max 4.5	3,500	2.06/(4.53)	97/(107)	13.0	1.3	1/4	10/(3/8)
Model Number	Punching cap	Cutting cap mm/(in.)	Weight kg/ (lb)	Vibration m/s <sup>2</sup>	Avg. Air Consumption CFM	Air Inlet Size in.	Hose Size mm/ (in.)	
SI-4800	ø5 x 1.2mm	1.2/(3/64)	1.01/(2.23)	< 2.5	1.3	1/4	10/(3/8)	

# OTHERS ACCESSORIES

## 400-8

Retaining Spring



01

## 820-11

Needle

ø3 x 180mm



12 Needles / product

02

# MAINTENANCE CHECK

## AIR TOOLS

In order to have a tool safely used with enough performance, please read the following contents well, understand them and use tools.

## WORK STATIONS

The tool should only be use as a handheld tool. It is always recommended that the tool is used when standing on a solid floor. It can be used in other positions, but before any such use the operator must be in a secure position having a firm grip and be aware of the extra safety precaution required when using this kind of tools.

## AIR SUPPLY

Use a clean lubricated air supply that will give a measured air pressure at the tools of 0.63Mpa(6.3 bar/90PSI) when the tool is running with the trigger depressed. Use recommended hose size and length. It is recommended that the tool is connected to the air supply as shown in the figure. Don't connect the tool to the airline system without incorporating an easy to reach and operate air shut off valve. The air filter, regulator and lubricated air at the correct pressure to the tool. Details of such equipment can be obtained from your supplier. If such equipment is not used then the tool should be lubricated by operator before/after using the tool. Disconnect the airline and pour into the inlet bushing 5ml of the suitable pneumatic oil preferably incorporating a rust inhibitor. Reconnect tool to air supply and run tool slowly for a few seconds to allow air to circulate the oil.

### DESCRIPTION

Pressure at the working	0.63MPa (90PSI 6.3bar)
Max Hose Length	10m (30ft)
Lubrication	Daily Lubricating oil

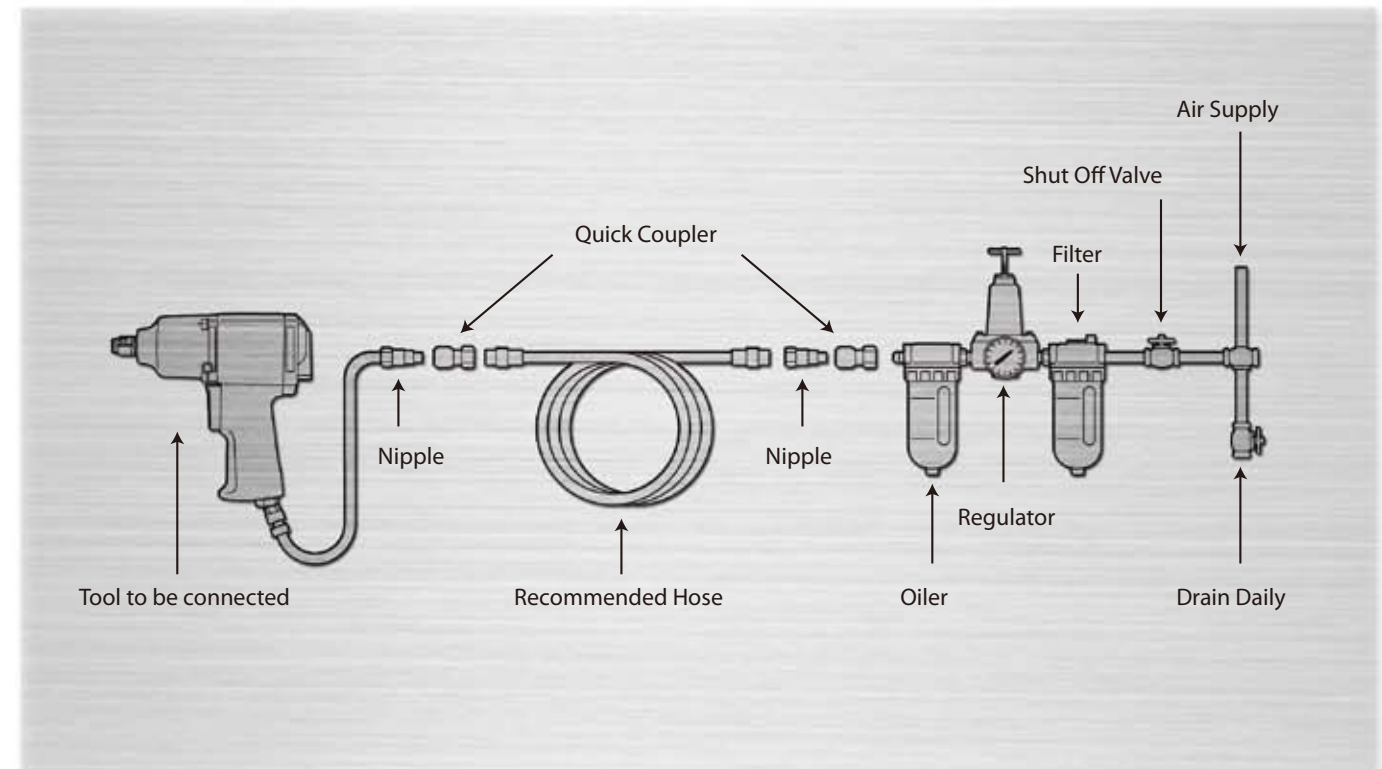



Planning And Development

For Customer's Satisfaction

In our products planning meetings our professional staff analyzes data from pertinent industries.

We discuss product concepts, target markets, sales prices, designs, functions, specifications and timing of introductions.



Designing

For Highest Perfection

In designing, we carefully study the properties of each part.

We examine the matings of each component in an assembled motor, and test the strength.

Our designers always aim for perfection in their designs which may eliminate inspections of product.

Our designs are based on ergonomics. "SI" collects data and tests experiments for safety, health and higher productivity.



Production

More Accurate, Rapid And Efficient

We are innovating our production lines to assist all automatic robotics in manufacturing products more accurately, rapidly and effectively.

We believe that it is important to combine a robot hand at high productivity with the management of the human mind, in order to sell quality products at an affordable price.



Inspection

To Certify The Quality

There is no need to inspect the function of each product because they have been carefully checked to produce perfection by design.

Our inspection of parts and products is not for defect detection, but to insure that the product meets the required quality and durability standard.

Our inspector's day-by-day studies assure you of higher quality of our products.

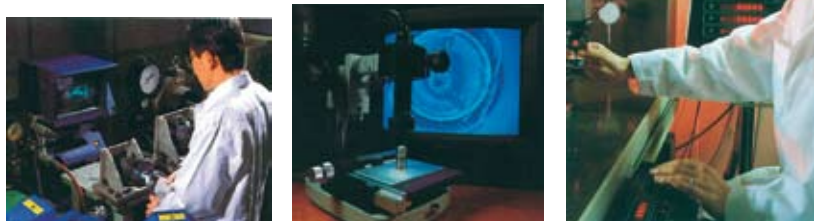

Exhaust Hose

TYPE-A

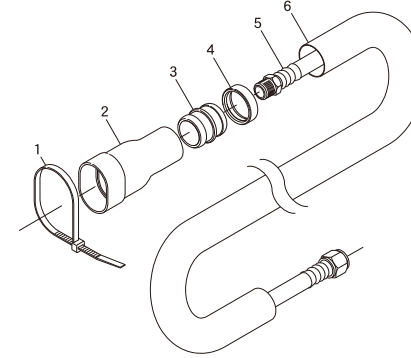

Ref. No.	Parts No.	Description	Q' ty
1	106-10	Harness Band	1
2	106-5	Exhaust Cover A	1
3	106-6	Connector	1
4	106-1	Urethane Band	1
5	106-3	Wipe Hose	1
6	106-2	Exhaust Hose	1

TYPE-B

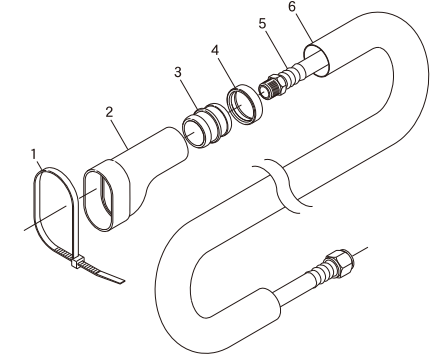

Ref. No.	Parts No.	Description	Q' ty
1	106-10	Harness Band	1
2	106-7	Exhaust Cover B	1
3	106-6	Connector	1
4	106-1	Urethane Band	1
5	106-3	Wipe Hose	1
6	106-2	Exhaust Hose	1

TYPE-D

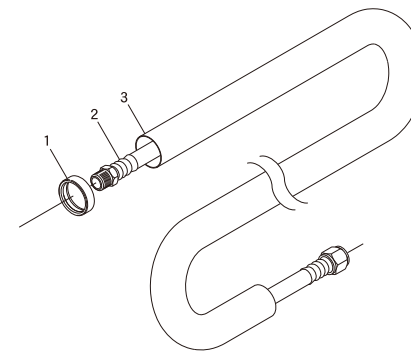

Ref. No.	Parts No.	Description	Q' ty
1	106-1	Urethane Band	1
2	106-3	Wipe Hose	1
3	106-2	Exhaust Hose	1

TYPE-S

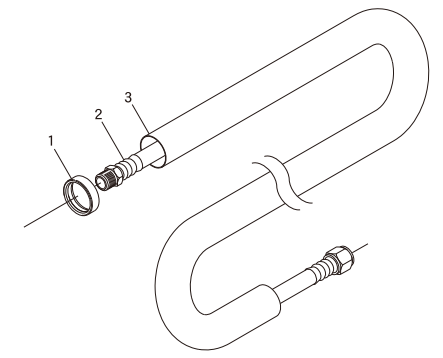

Ref. No.	Parts No.	Description	Q' ty
1	106-8	Urethane Band S	1
2	106-3	Wipe Hose	1
3	106-9	Exhaust Hose S	1

Exhaust House	IMPACT WRENCHES				DRIVERS				RATCHET WRENCHES				SANDERS				POLISHER											
	SI-1310	SI-1315	SI-1315S	SI-1480A	SI-1480SR	SI-1440T	SI-1090	SI-1070	SI-1369D	SI-1370D	SI-1161	SI-1169A	SI-106-30	SI-1340B	SI-2007A	SI-2008	SI-2110	SI-2026	SI-2001	SI-2002	SI-2051	SI-2100	SI-1700LS	SI-2060	SI-2030	SI-200A	SI-2221	
TYPE-A																												
TYPE-B																												
TYPE-D																												
TYPE-S																												

Exhaust House	DIE GRINDER/DISC GRINDER				DRILLS/SPOTMILLS				CUTTING TOOLS					
	SI-2001SA	SI-2002SA	SI-2003SA	SI-2004SA	SI-2005SA	SI-2006SA	SI-2007SA	SI-2008SA	SI-2009SA	SI-2010SA	SI-2011SA	SI-2012SA	SI-2013SA	SI-2014SA
TYPE-A														
TYPE-B														
TYPE-D														
TYPE-S														



GRINDERS



GRINDERS															
SI-20015-B	SI-2002	SI-20025	SI-20025-6	SI-2003	SI-20031	SI-20031L	SI-20031L	SI-20031L	SI-20031L	SI-20031L	SI-20031L	SI-20031L	SI-20031L	SI-20031L	SI-20031L

For Grinding

Part No.	Qty	Description	SI-20015-B	SI-2002	SI-20025	SI-20025-6	SI-2003	SI-20031	SI-20031L	SI-20031L	SI-20031L	SI-20031L	SI-20031L	SI-20031L	SI-20031L	SI-20031L
330-24	01	1/4" Collet														
330-19	02	6mm Collet														
330-25	03	1/8" Collet														
330-26	04	3mm Collet														
210-5-A	05	Dead handle set														
175-29	06	3" Cut disk														
240-6	07	4" Disc 15mm Hole														
240-71	08	4" Disc 16mm Hole														
240C-1	09	Disc Nut for 16mm Hole														
380-44	10	Disc Nut for 15mm Hole														
241-49	11	5" Disc														
280-28	12	7" Disc														
340-57	13	30 φmm Grindstone														
340-2A	14	3mm Collet														
340-2B	15	1/8" Collet														
340-55	16	φ5mm Grindstone														

POLISHER



POLISHER		
SI-22415	SI-22221	SI-2009H

ROUND TYPE (NO HOLE)

M-150H	01	6" Velcro Pad																		
--------	----	---------------	--	--	--	--	--	--	--	--	--	--	--	--	--	--	--	--	--	--

ROUND TYPE MINI PAD (NO HOLE)

114DA-12	02	φ3" Velcro Pad Thread 6mm																		
----------	----	---------------------------	--	--	--	--	--	--	--	--	--	--	--	--	--	--	--	--	--	--

BUFF & MINI BUFF

Part No.	Qty	Description	SI-22415	SI-22221	SI-2009H
M-40x165/B	03	Sponge Buff			
M-150	04	Wool Buff			
M-75H	05	3" Velcro Pad 5/16-24UNF			
119-101	06	φ80mm Sponge Buff			
119-102	07	φ80mm Wool Buff			
NVP75-240	08	φ75mm Sanding Paper #120			
1145-101	09	φ165mm Wool Buff			
1145-102	10	φ165mm Sponge Buff			

CUTTING TOOLS

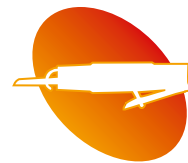

CUTTING TOOLS					
SI-47005	SI-4710	SI-4710F	SI-4730	SI-4800	SI-2010A-6

For Cutting

Part No.	Qty	Description	SI-47005	SI-4710	SI-4710F	SI-4730	SI-4800	SI-2010A-6
506-49A	01	Saw blade 32T						
1025-49	02	Saw blade 32T						
1025-50	03	Saw blade 24T						
506P-56F	04	Flat File						
506P-56R	05	Round File						
506P-56T	06	Triangle File						
160-2	07	Center Blade						
160-3	08	Right Blade						
160-4	09	Left Blade						
502-42	10	Punch						
502-41	11	Die						
508-45A	12	Cutting Wheel						
508-45B	13	Cutting Blade						
330-24	14	1/4" Collet						
330-19	15	6mm Collet						
330-25	16	1/8" Collet						
330-26	17	3mm Collet						
508-44	18	Adjuster						

DRILLS/SPOTMILLS



DRILLS/SPOTMILLS					
SI-5100A	SI-5200A	SI-5305A	SI-5501	SI-5500	SI-5500A

Drilling, Milling, Trimming

Part No.	Qty	Description	SI-5100A	SI-5200A	SI-5305A	SI-5501	SI-5500	SI-5500A
KD-004	01	3/8" Drill Chuck						
LX10	02	3/8" Keyless Chuck (Yukiwa)						
LM13W	03	1/2" Keyless Chuck (Yukiwa)						
KD-003A	04	1/2" Drill Chuck						
KD-002	05	3/8" Drill Chuck						
KK	06	Chuck Handle for KD-004, & KD-003A						
KG1	07	Chuck Handle for KD-002						
100	08	Collet Driver						
271-17	09	φ8mm milling Cutter						
271-70	10	φ6.5mm Milling Cutter						
271-71	11	Sleeve φ6.5 Milling Cutter						
210-5-1A	12	Dead handle set						

OTHERS



OTHERS	
SI-4150	SI-4120A

For punching, Trimming

Part No.	Qty	Description	SI-4150	SI-4120A
400-8	01	Retaining Spring		
820-11	02	Needle φ3x180mm		

IMPACT DRIVERS



IMPACT DRIVERS	
SI-1055	SI-1055D

REGULATOR

Part No.	Qty	Description	SI-1055	SI-1055D
181-45	01	Regulator		
458-58	02	Housing Cover		

SANDERS



ROUND TYPE (NO HOLE)

SANDERS																												
M-75H	P-75H	ME-125H	PE-125H	M-150H	P-150H	257-2A	486-3	M-75HD	P-75HD	ME-125HD	PE-125HD	M-150HD 6	P-150HD 6	M-150HD 9	P-150HD 9	1140-14M	1140-59M	M-3003	P-3003	M-3007	P-3007	M-3013D	P-3013D	475-22	477A-SEM	477A-SEL		
01	02	03	04	05	06	07	08	09	10	11	12	13	14	15	16	17	18	19	20	21	22	23	24	25	26	27	28	29

ROUND SHAPE PAD WITH HOLES

SANDERS																										
M-75HD	P-75HD	ME-125HD	PE-125HD	M-150HD 6	P-150HD 6	M-150HD 9	P-150HD 9	1140-14M	1140-59M	M-3003	P-3003	M-3007	P-3007	M-3013D	P-3013D	475-22	477A-SEM	477A-SEL	MESP-65	262-21MD	SHP-50M	114DA-12	M-20x60B	M-60		
09	10	11	12	13	14	15	16	17	18	19	20	21	22	23	24	25	26	27	28	29	30	31	32	33	34	35

SQUARE TYPE (NO HOLE) & SQUARE TYPE PAD WITH HOLES

SANDERS																							
M-3003	P-3003	M-3007	P-3007	M-3013D	P-3013D	475-22	477A-SEM	477A-SEL	MESP-65	262-21MD	SHP-50M	114DA-12	M-20x60B	M-60									
21	22	23	24	25	26	27	28	29	30	31	32	33	34	35									

MINI PAD & BUFF & DISC

SANDERS																							
MESP-65	262-21MD	SHP-50M	114DA-12	M-20x60B	M-60																		
30	31	32	33	34	35																		

TRIANGLE TYPE & DUST CHIP ELIMINATOR PAD

SANDERS																							
118-3A	310GS-4	310GS-5																					
36	37	38																					

WET SANDER PAD

SANDERS																							
1110A-80	1110A-80E																						
39	40																						

REGULATOR

SANDERS																							
181-45	41																						
Regulator																							

※5/16-24UNF

IMPACT WRENCHES



IMPACT WRENCHES				
SI-1385	SI-1610	SI-1610SR	SI-1482A	SI-1482ASR

MUFFLER & RETAINER FOR IMPACT WRENCHES

Part No.	Qty	Description	SI-1385	SI-1610	SI-1610SR	SI-1482A	SI-1482ASR
103-1	01	Muffler					
911P-25	02	Muffler					
215RA-15	03	Muffler Filter inside (quieter than 911P-25)					
911A-15	04	Muffler Retainer					
736-8	05	Muffler Retainer					
911P-11	06	Retainer					
736DH-10	07	Retainer					
458-58	08	Housing Cover					



**SHINANO**  
PNEUMATIC TOOLS  
<http://www.shinainc.com/>

